

7 kg
15 lbs

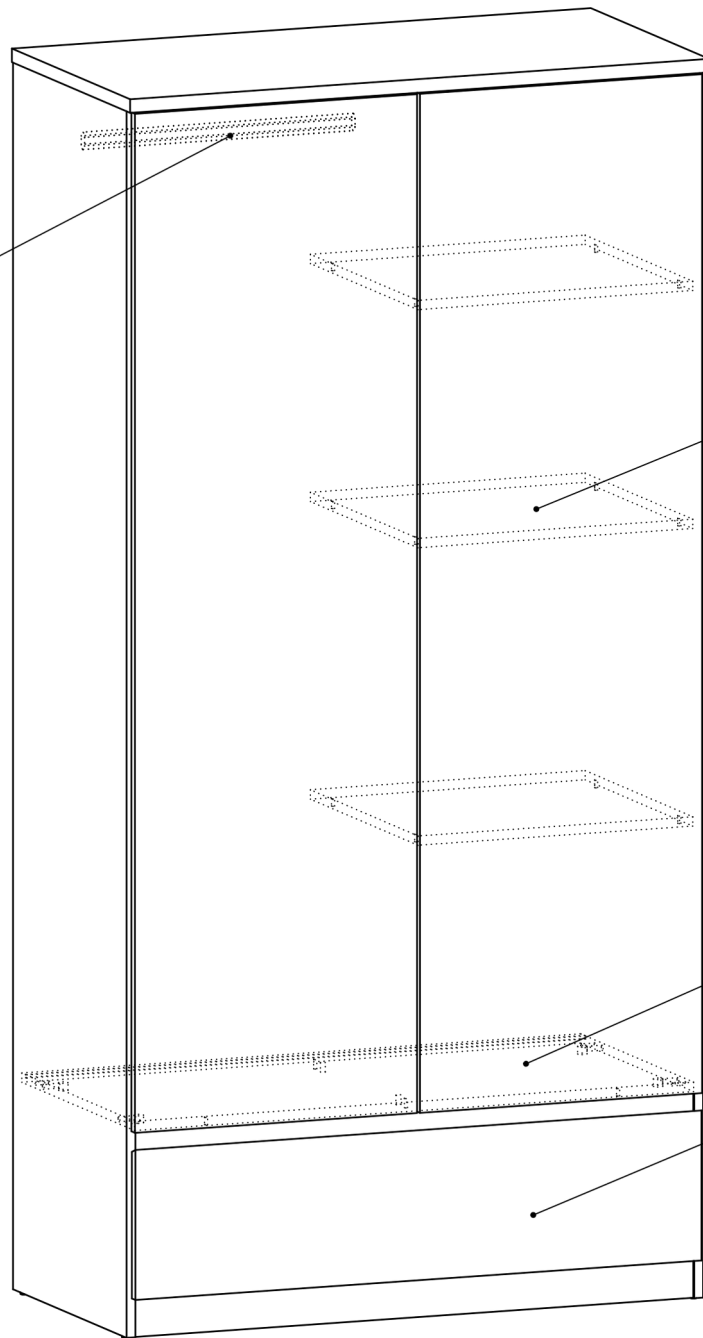

17 kg
37 lbs

14 kg
31 lbs

9 kg
20 lbs

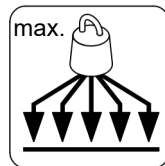

70287 B

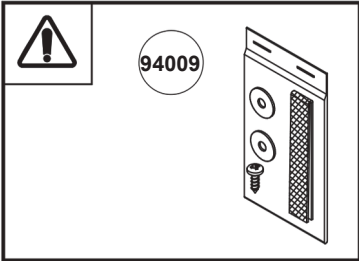

Dansk (da)
VISNING: Skruen som følger med væltesikringen er kun til at fæstne væltesikringen i møbel. Du skal derfor supplere med en skrue eller et beslag som passer til det materiale din væg er lavet af. Hvis du er usikker så kontakt din lokale fagmand.

Dansk (da)

Norsk (no)
VISNING: Legg merke til at skruen som følger med tippebeskyttelsen kun skal brukes for å feste tippebeskyttelsen i møbelet. Kompletter derfor med en skrue eller et fesebeslag tilpasset materialet i veggen din. Er du usikker, ta kontakt med din lokale fagforhandler.

Svenska (sv)
BESENING: Att skruven som medföljer tipskyddet endast ar avsedd för att fasta tipskyddet i möbeln. Komplettera därför med en skruv eller ett fastbeslag som passar materialet i din vägg. Är du osaker kontakta din lokaia fackhandel.

Svenska (sv)

Svenska (sv)

Svenska (sv)

Suomi (fi)
HUOMIO: Ota turvakiinnikkeen mukana tuleva ruuvi on tarkoitettu ainoastaan kiinnittäkseen turvakiinnikkeen huonekaluun. Täydennä sen vuoksi ruuvilla tai muulla kiinnityksellä joka sopii seinäsi materiaaliin. Ota yhteyttä tavaramallin, jos olet epävarma.

Nederlands (nl)
BELENGING: De schroeven die bij de wandbevestiging zitten, zijn uitsluitend bedoeld om de wandbevestiging aan het meubel te bevestigen. Completeer de wandbevestiging met een schroef of bevestigingsbeslag dat geschikt is voor het materiaal van de wand. Neem bij twijfel contact op met de ijzerhandel.

Français (fr)
IMPORTANT: Les vis fournies avec le dispositif anti basculement sont à fixer sur le meuble. Pour la fixation au mur, complétez par une vis adaptée au support mural.

Portugals (pt)
IMPORTANTE: O parafuso de suporte, contactar um magasin de bricolage.
UWAGA!W komplecie z mocowaniami zapobiegającymi wywróceniu mebla są śruby, które służą tylko do przytwierdzenia ich do mebla. Rodzaj śrub przytwierdzających je do ściany zależy od rodzaju materiału z jakiego została wykonana (gips, cegła, drewno itd.). Będą więc potrzebne dodatkowo odpowiednie śruby. Jeśli masz wątpliwości co do rodzaju śrub zasięgnij opinii fachowca.
BELENGING: Šroub přibalený k bezpečnostnímu kování je určen pouze k přichycení kování k nábytku. Je nutné, zvolit šroub k přichycení kování ke stěně, který je vhodný vzhledem k typu vaší shěny. V případě, kdy si nejste jisti, jaký šroub použít, žádejte o radu v nejbližším obchodě železářství nebo v obchodě domácích potřeb.

Magyar (hu)
FIGYELÉS! A dőlést megakadályozó tartóhoz kapott csavar kizárólag a tartó bútorhoz történő rögzítéséhez használható. Ezen felül ki kell választania, hogy milyen csavart vagy szerelvényt használjon ahhoz a falhoz, ahova a tartókart rögzíteni szeretné. Amennyiben nem biztos benne, hogy milyen csavart kell használnia, lépjen kapcsolatba a helyi vasárubolttal.

DOLEŽITÉ UPOZORNENIE. Skrutka dodávaná spolu s bezpečnostným kovaním je určená iba na upevnenie kovania k nábytku. okrem toho budete potrebovať skrutku za prichytenie kovania k stene. Túto si vyberte podra druhu steny. AK si nie ste istý, aký, druh skrutky potrebujete, kontaktujte najbližszsie železiarstvo.

Slovensčina (sl)
POZOR!Priloženi vijak, skupaj z nosilcem za pritrditev proti prevrnitvi, je namenjen izključno pritrjevanju nosilca za pritrditev proti prevrnitvi na pohištvo. Poleg tega boste potrebovali tudi ustrezen vijak oz. element za pritrjevanje nosilca na vaš tip stene. Če niste prepričani o tem, kakšen vijak je najprimernejši, se obrnite na eno od tehničnih trgovin v vaši bližini.

VARNING: Isporučeni vijak i sigurnosni nosač treba upotrijebiti samo za pričvršćivanje sigurnosnog nosača na namještaj. Uz to, morat ćete odabrati vijak ili spojni element prikladan za pričvršćivanje nosača na odgovarajuću vrstu zida. Ako niste sigurni koju vrstu vijka trebate upotrijebiti, pitajte u lokalnoj trgovini železarijom.

Русский (ru)
ВАЖНО! Болт, поставляемый вместе с держателем против опрокидывания, должен использоваться только для крепления данного держателя к мебели. В дополнение к этому необходимо подобрать шуруп или крепление для фиксации держателя на стене в зависимости от ее типа. Если вы не уверены, какой шуруп использовать, обратитесь за консультацией в местный магазин строительных товаров.

Bosanski (bs)

Važno: Vijak priložen uz nosač sa zaštitom od prevrtanja je namijenjen samo za pričvršćivanje nosača na namještaj. Uz to bit će potrebno da odaberete vijak ili

spojni element pogodan za pričvršćivanje nosača na odgovarajuću vrstu zida. Ako niste sigurni koju vrstu vijka odabrati pitajte u lokalnoj prodavaonici građevinskog materijala.

Svenska (sv)

Svenska (sv)
BESENING: Den fjärrskruven som följer med säkerhetsfästet ska endast användas för att fästa säkerhetsfästet i möbelen. Du behöver komplettera med en skruv eller ett fastbeslag som passar till ditt material. Om du är osäker kontakta din lokala fackhandel.

ВАЖНО! Болт, який постачається разом з тримачем від перекидання, повинен використовуватися тільки для кріплення цього тримача до меблів. Крім цього, необхідно підібрати шуруп або кріплення для фіксації тримача на стіні, залежно від її типу. Якщови не впевнені, який шуруп використовувати, зверніться за консультацією до місцевого магазину будівельних товарів.
IMPORTANT! Şurubulturnizat împreună cu consola anti-răsturnare va fi utilizat doar pentru fixareaconsoleianti-răsturnare pe mobilă. Pe lângă aceasta, va trebui să alegeți un şurubsaumontură adecvate pentru fixarea consolei pe tipul de perete din încăperearespectivă.Dacă aveți nelămuriri privind tipul de şurub de utilizat contactați un magazinlocalde scule și unelte.

ВАЖНО! Доставкаиятвинт, заедно с крепежата скоба, се използва единствено за закрепване накрепящата скоба към мебелите. Освен това Вие ще трябва да изберете винт илифитинг, който е подходящ за закрепване на скобата към вида на Вашистенени.Ако не сте сигурни какъв вид винт да използвате, можете да се местниямагазин за инструменти за дома.

ΣΗΜΑΝΤΙΚΟ! Η βίδα που παρέχεται μαζί με το αντιανταρρεπτικό στηρίγμα πρέπει να χρησιμοποιηθεί μόνο για τη στερέωση του αντιανταρρεπτικού στηρίγματος στο έπιπλο. Εκτός από αυτή τη βίδα, θα χρειαστείτε μία βίδα ή εξάρτημα που είναι κατάλληλο για τη στερέωση του στηρίγματος στο είδος του τοίχου που έχετε. Εάν δεν είστε σίγουροι για τον τύπο της βίδας που πρέπει να χρησιμοποιήσετε, επικοινωνήστε με ένα σιδηροπωλείο.

Svenska (sv)

Svenska (sv)

Svenska (sv)

Svenska (sv)

Svenska (sv)

Svenska (sv)

Svenska (sv)

Svenska (sv)

Svenska (sv)

Svenska (sv)

Svenska (sv)

Svenska (sv)

Svenska (sv)

Svenska (sv)

Svenska (sv)

Svenska (sv)

Svenska (sv)

Svenska (sv)

Svenska (sv)

Svenska (sv)

Svenska (sv)

Svenska (sv)

Svenska (sv)

Svenska (sv)

Svenska (sv)

Svenska (sv)

Svenska (sv)

Svenska (sv)

Svenska (sv)

Svenska (sv)

Svenska (sv)

Svenska (sv)

Svenska (sv)

Svenska (sv)

Svenska (sv)

Svenska (sv)

Svenska (sv)

Svenska (sv)

Svenska (sv)

Svenska (sv)

Svenska (sv)

Svenska (sv)

Svenska (sv)

Svenska (sv)

Svenska (sv)

Svenska (sv)

Svenska (sv)

Svenska (sv)

Svenska (sv)

Svenska (sv)

Svenska (sv)

Svenska (sv)

Svenska (sv)

Svenska (sv)

Svenska (sv)

Svenska (sv)

Svenska (sv)

Svenska (sv)

Svenska (sv)

Svenska (sv)

Svenska (sv)

Svenska (sv)

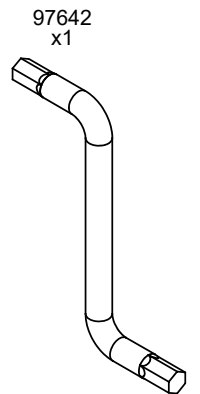
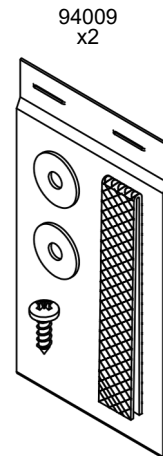
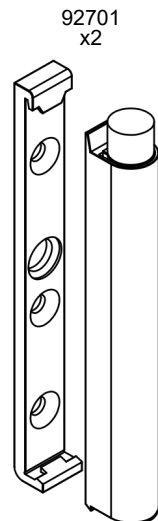
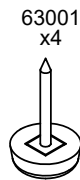
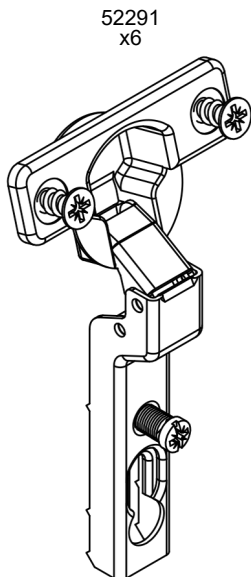
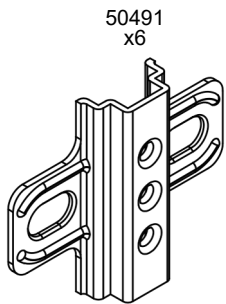
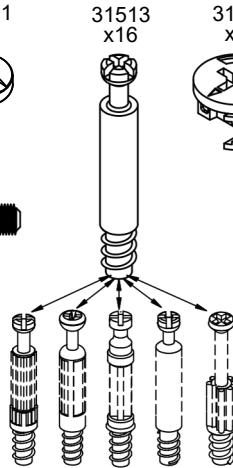
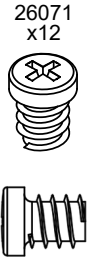
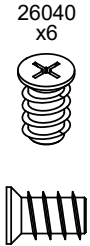
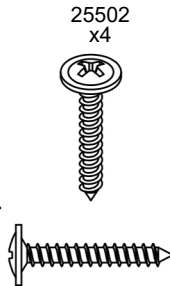
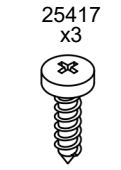
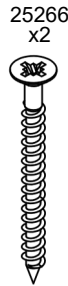
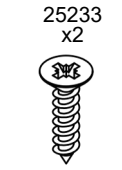
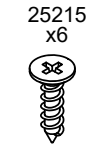
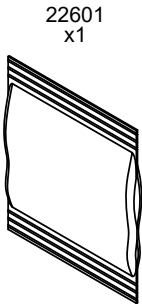
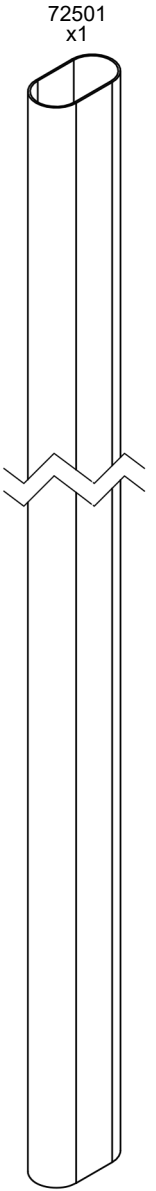
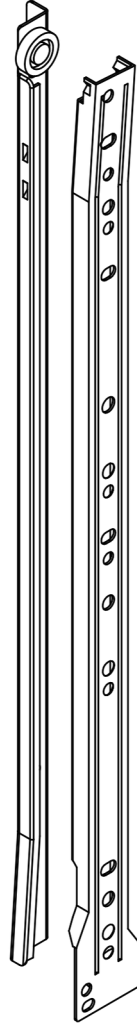
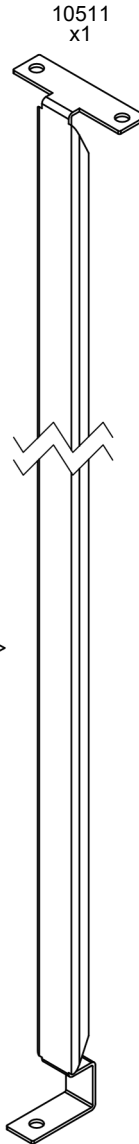
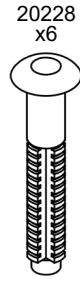
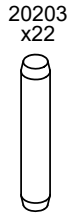
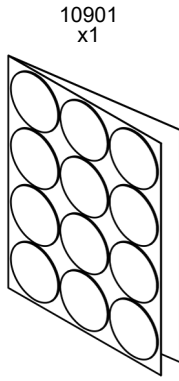
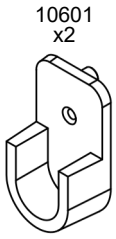
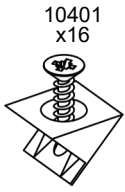
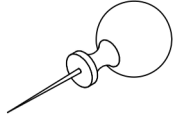
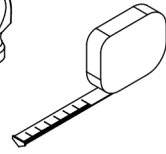
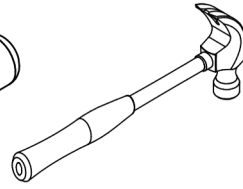
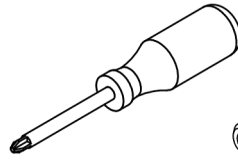
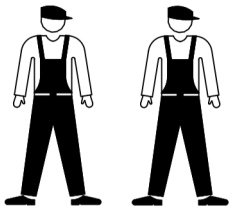

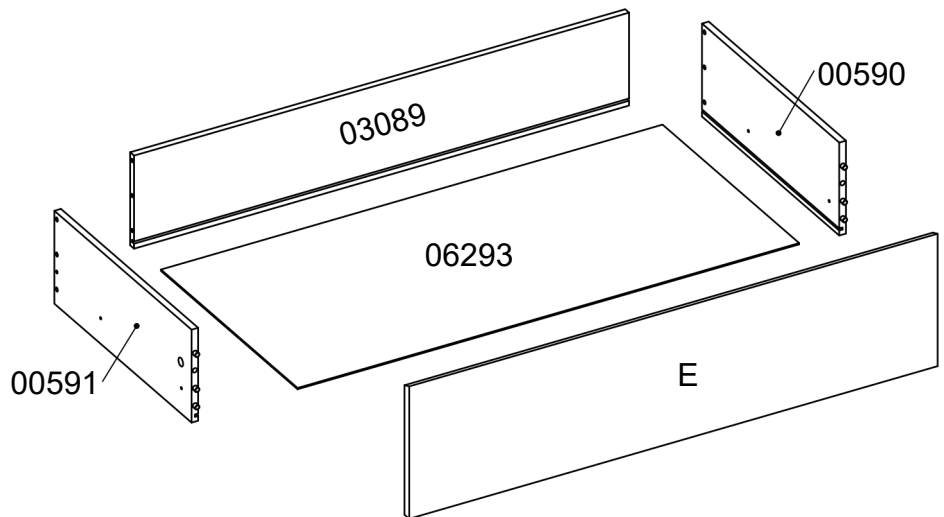
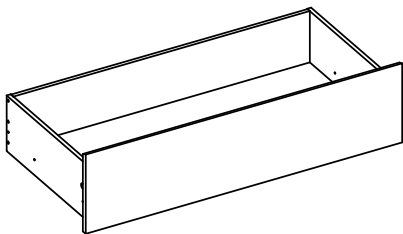
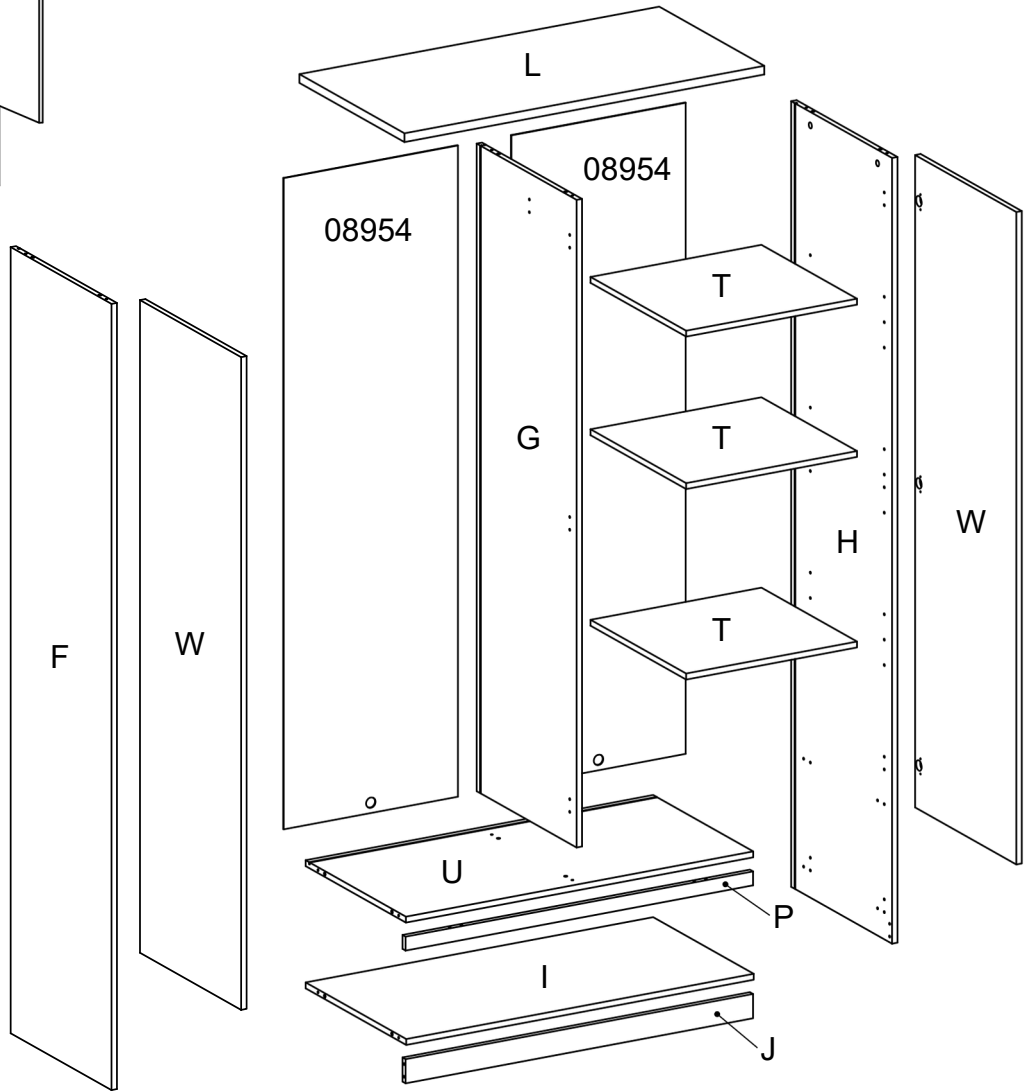
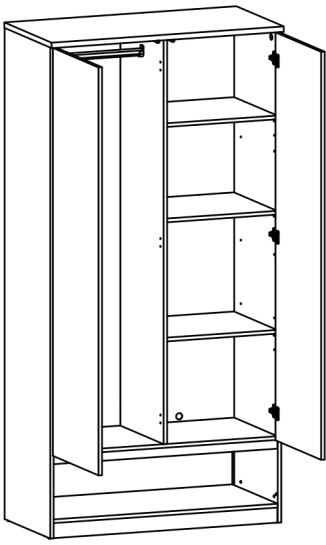

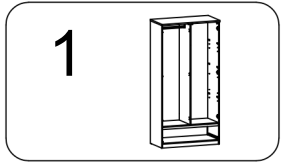

20203
x16



31687
x14

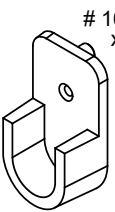
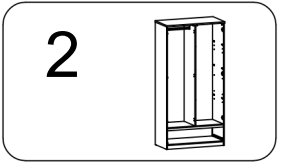
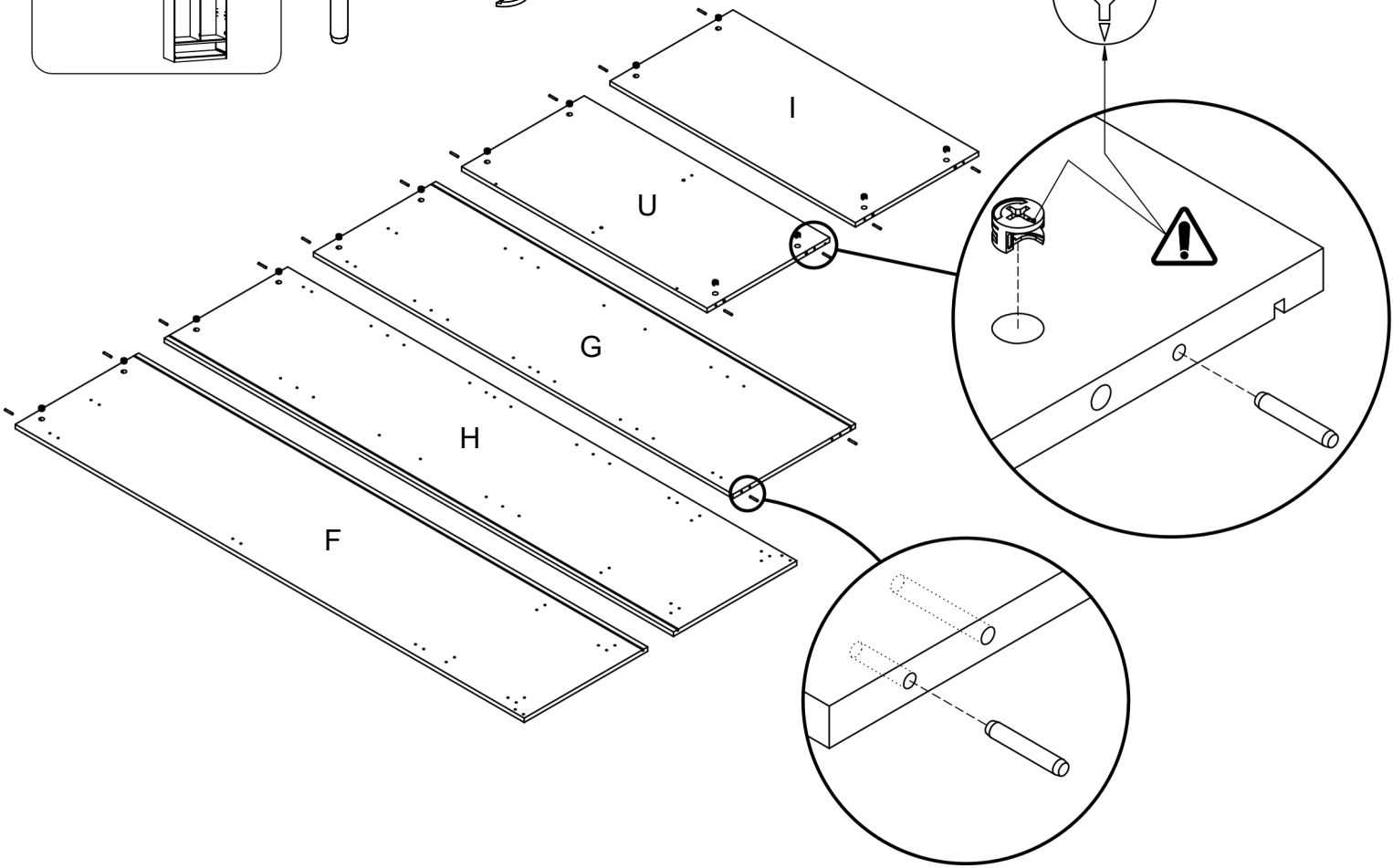

10601
x2



25215
x2

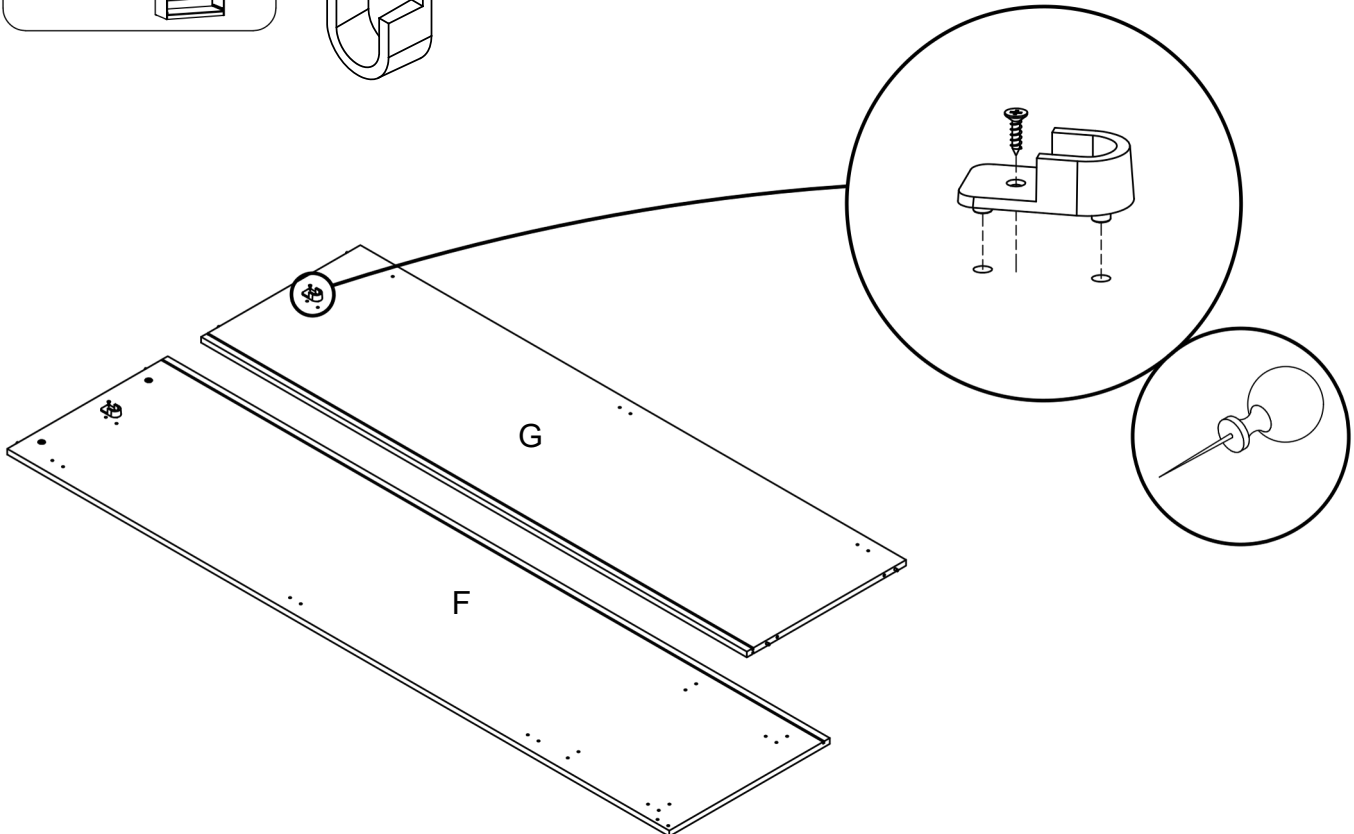

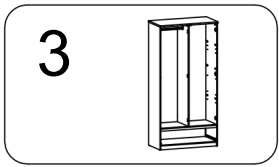

25233
x2

26040
x4

41642
x1

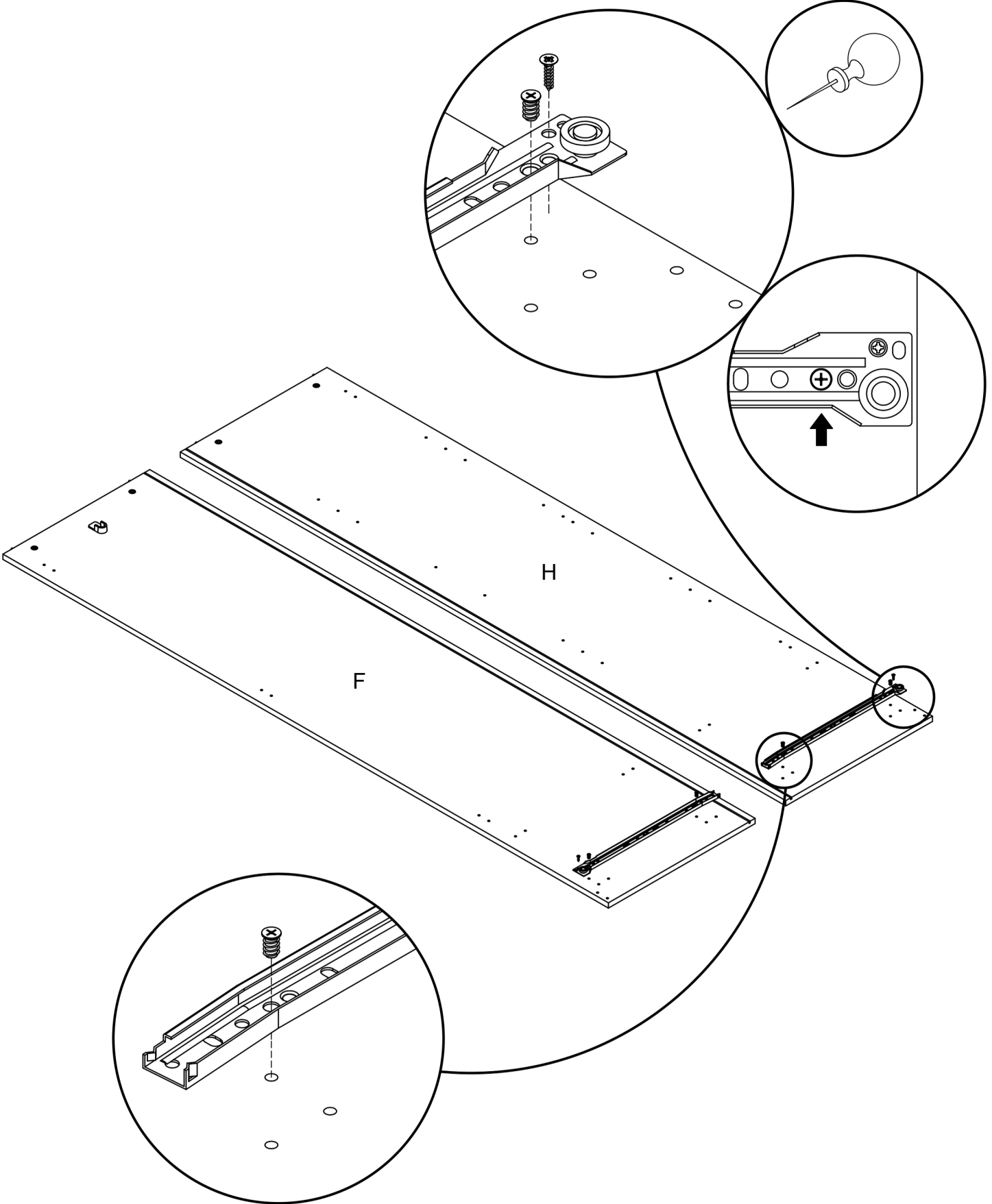
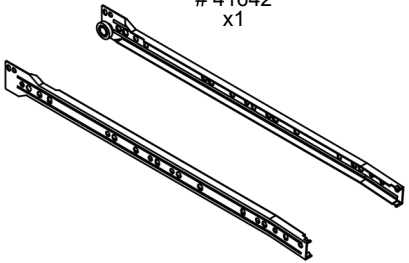

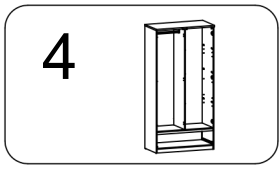

26071
x12

26211
x6

50491
x6

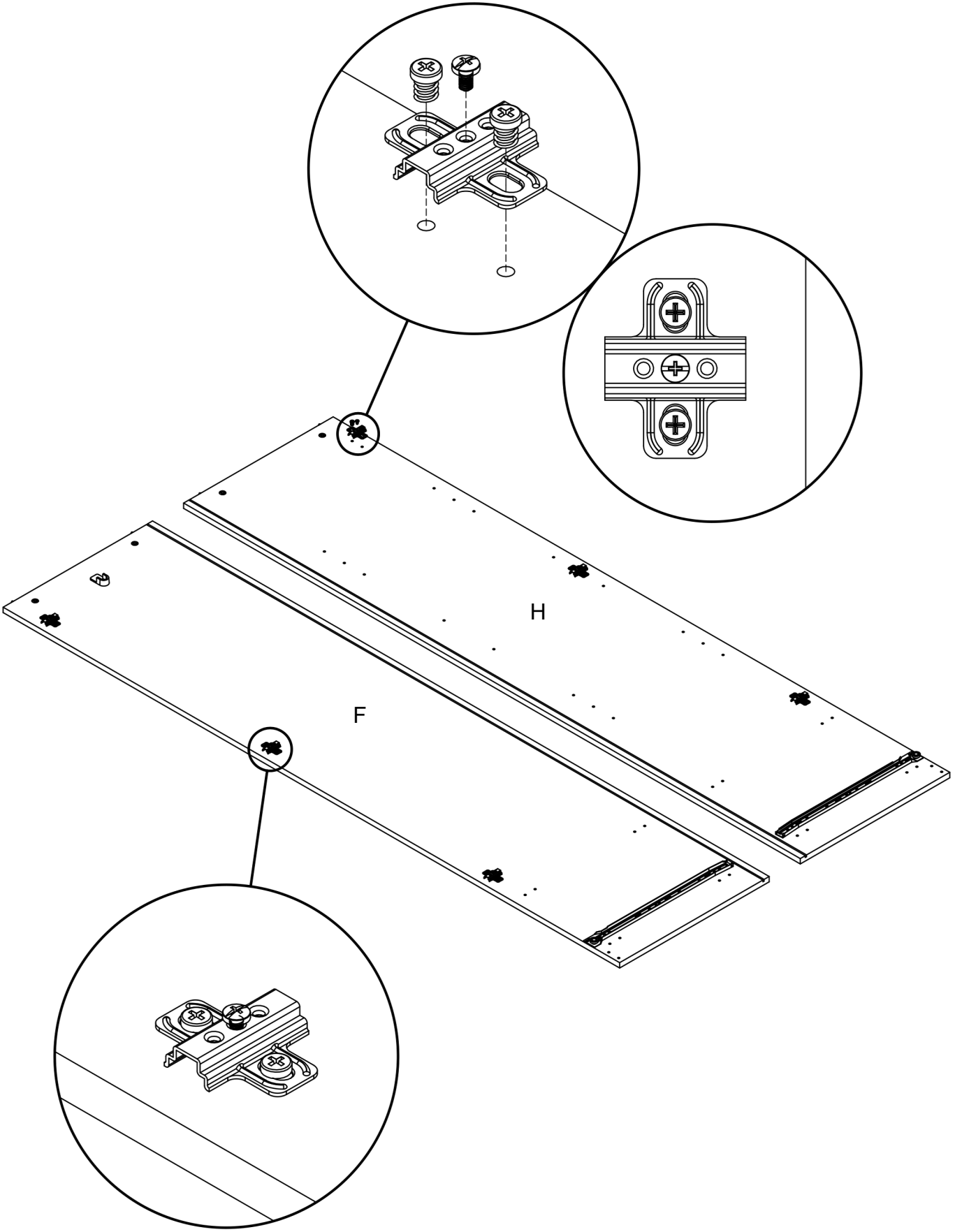

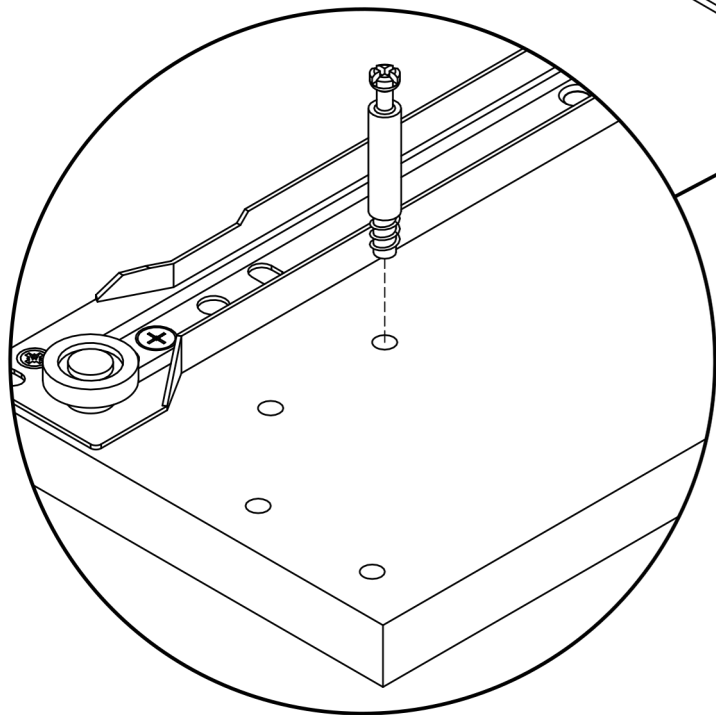
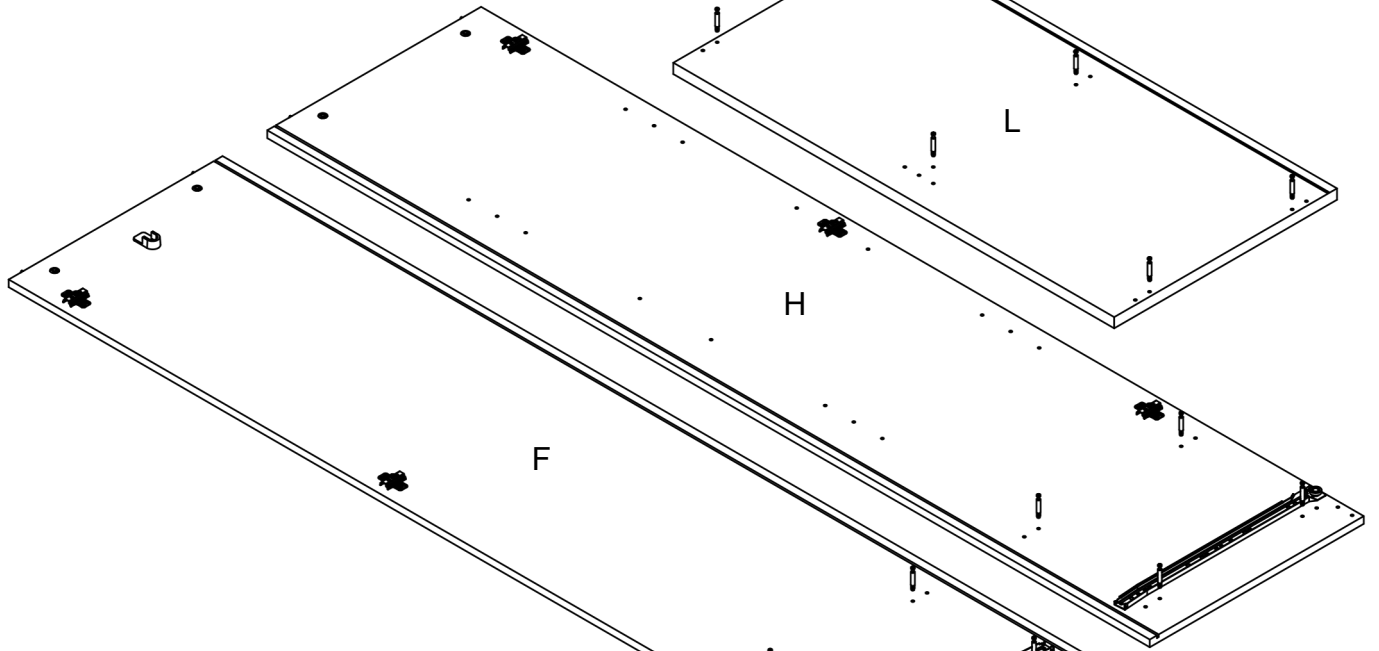
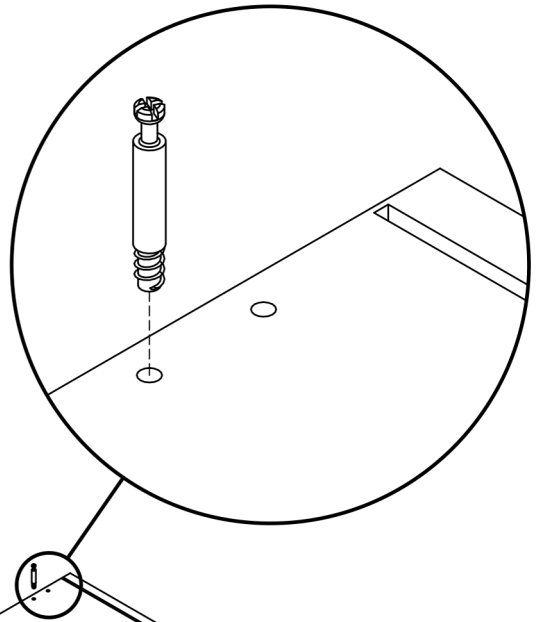
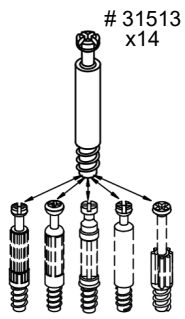
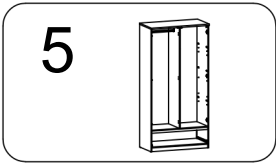

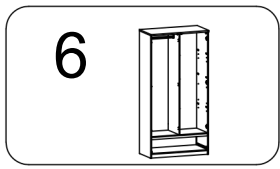

20203
x6

22601
x1

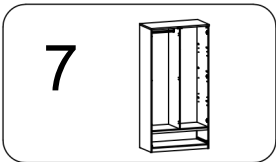
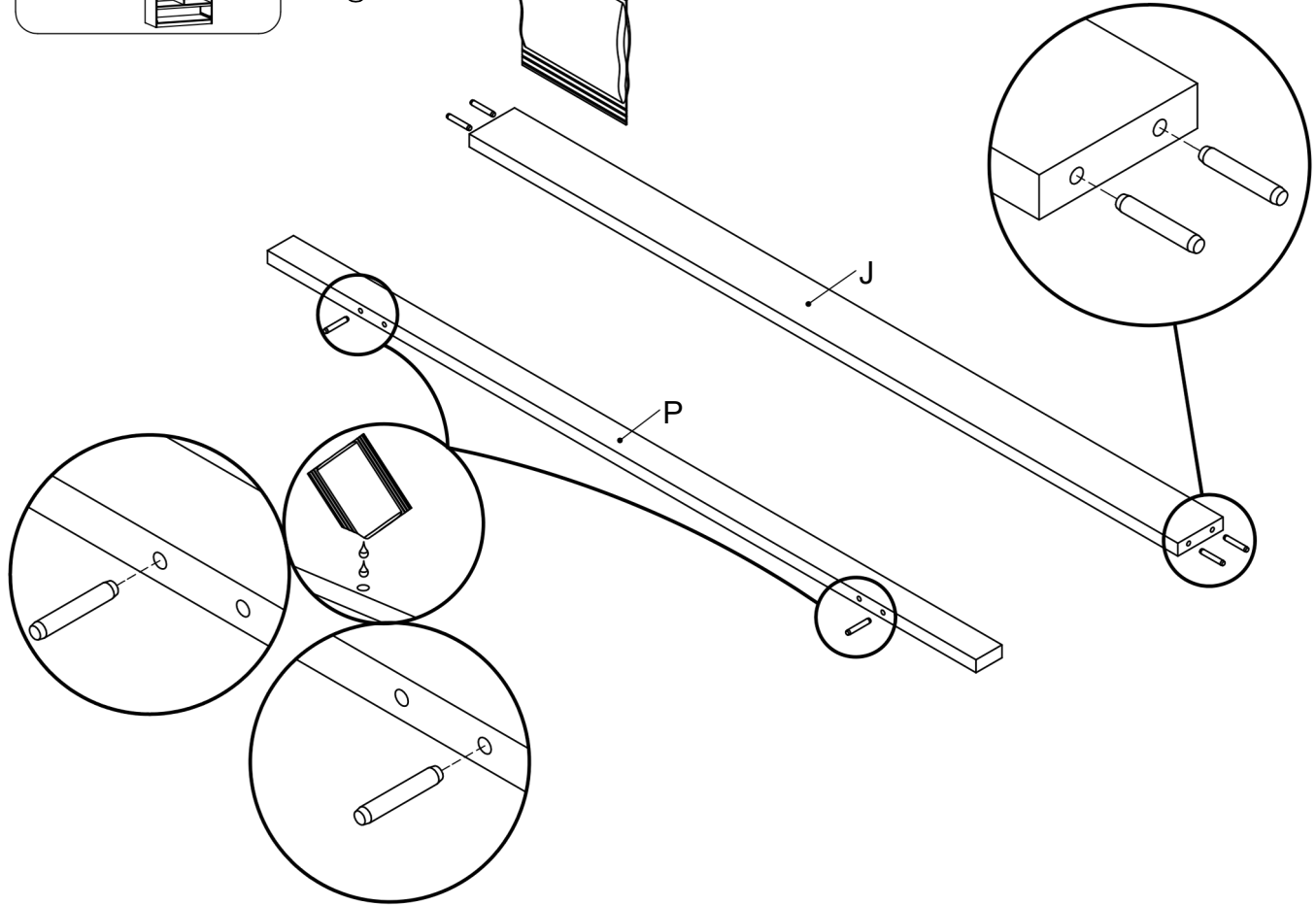

25266
x2

22601
x1

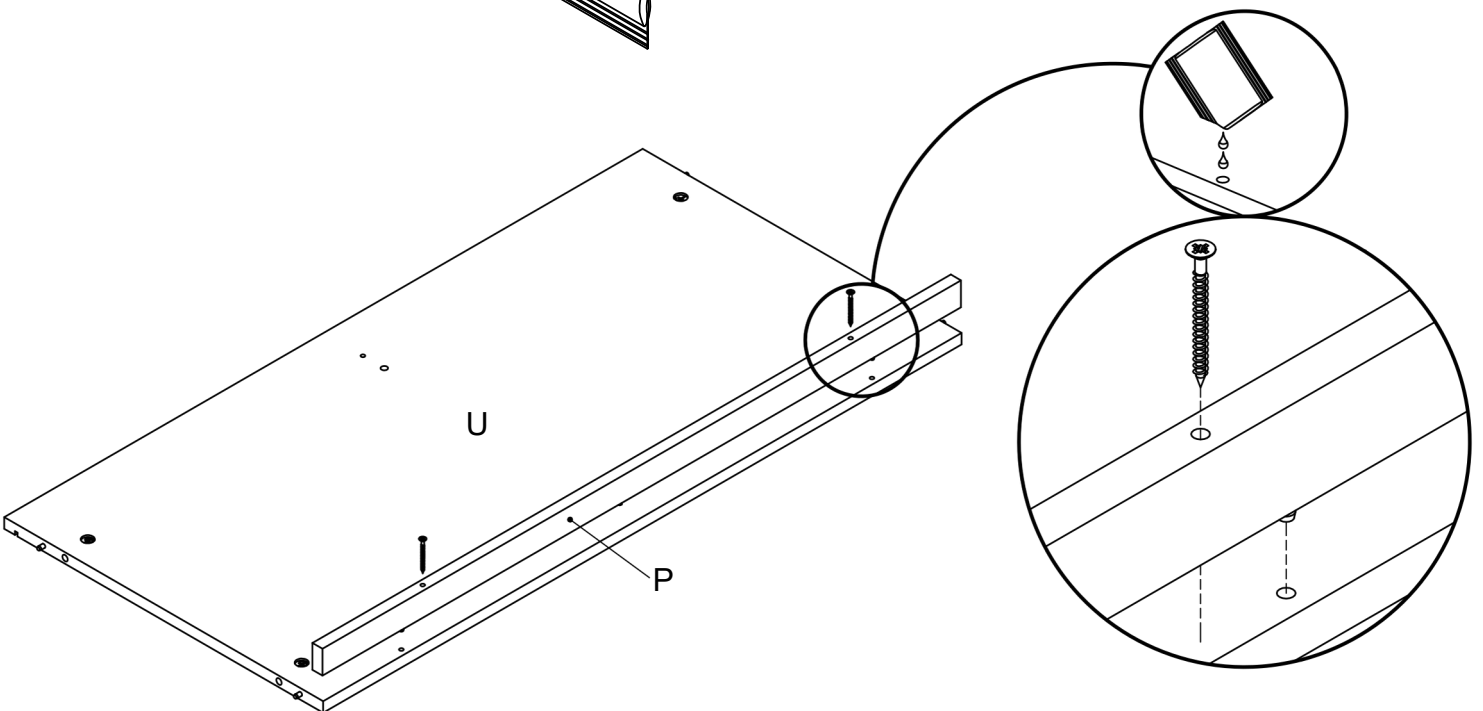

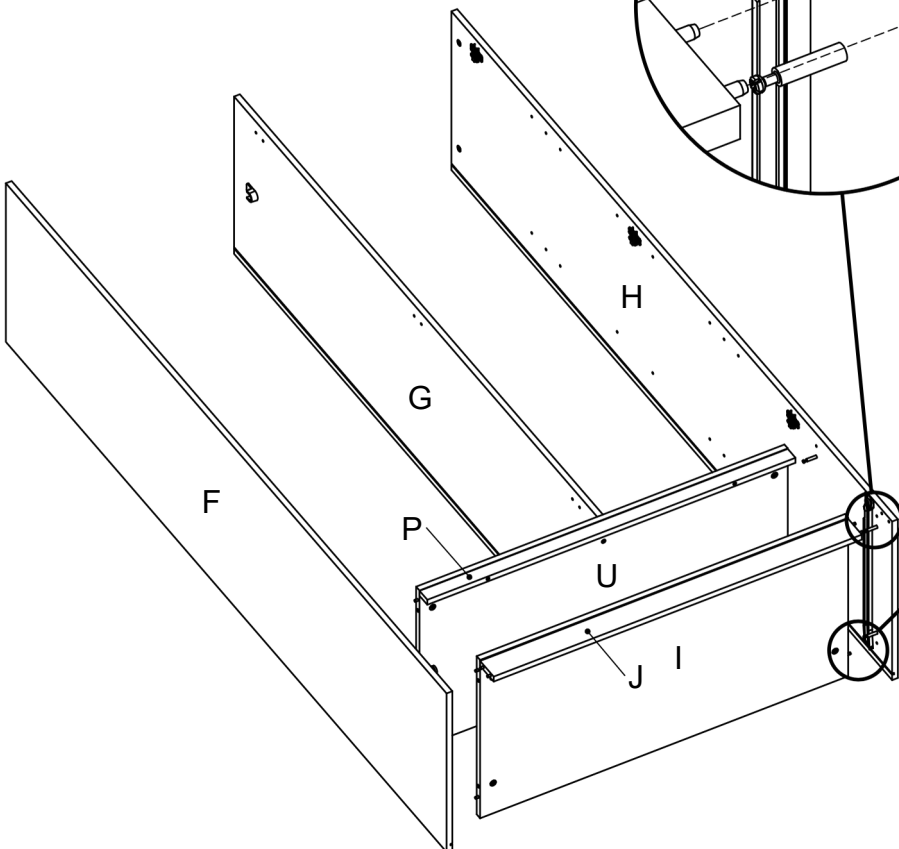
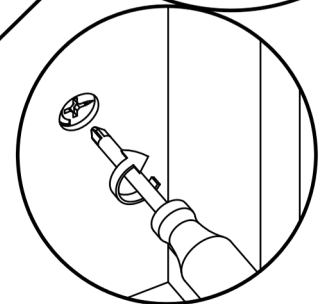
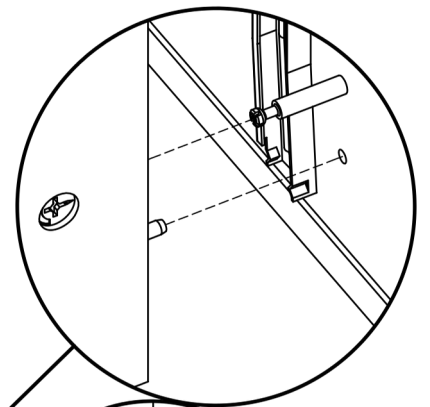
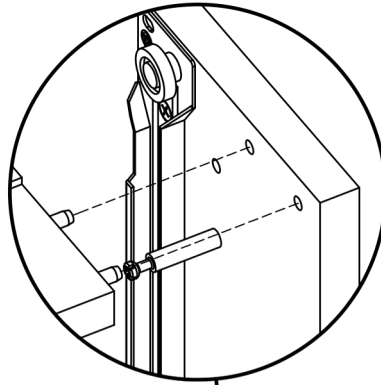
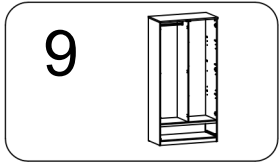
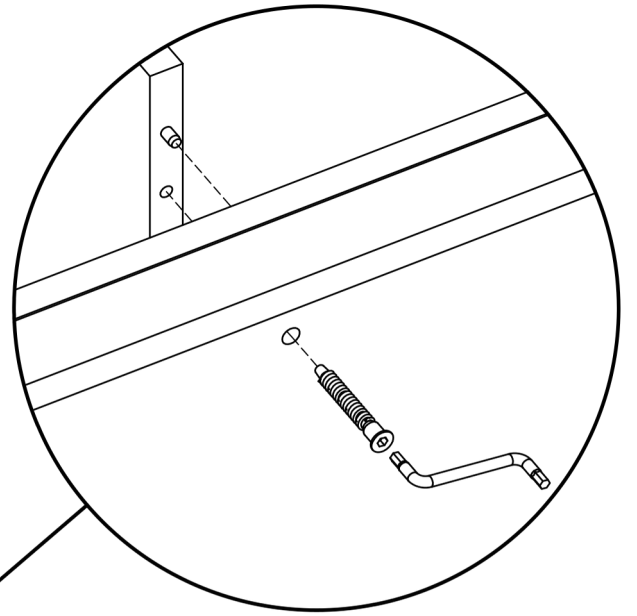
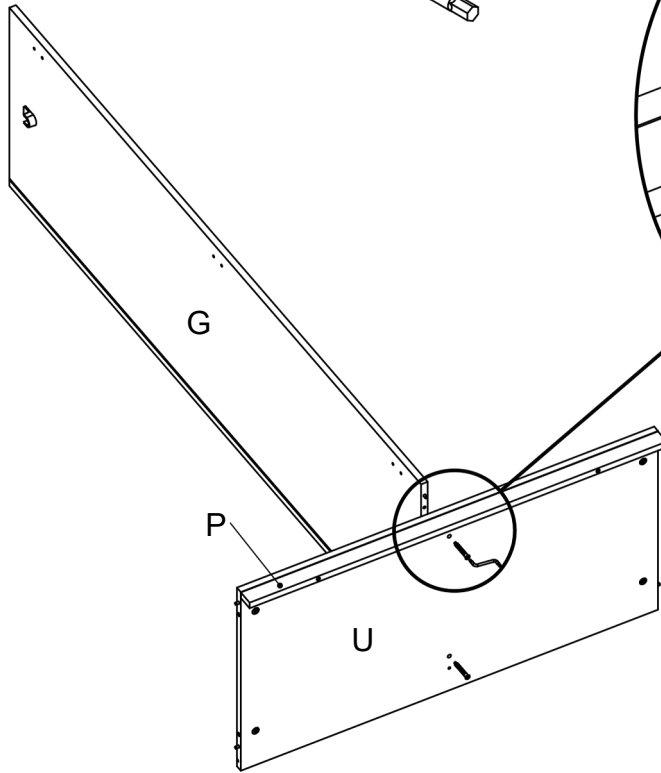
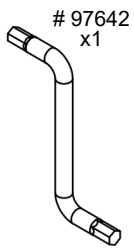
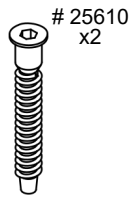
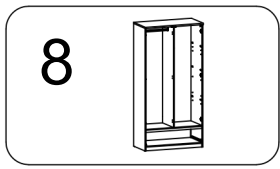

10

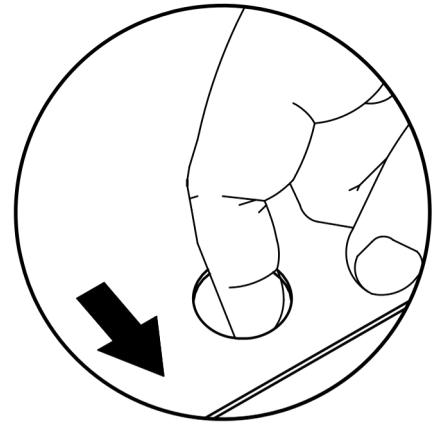
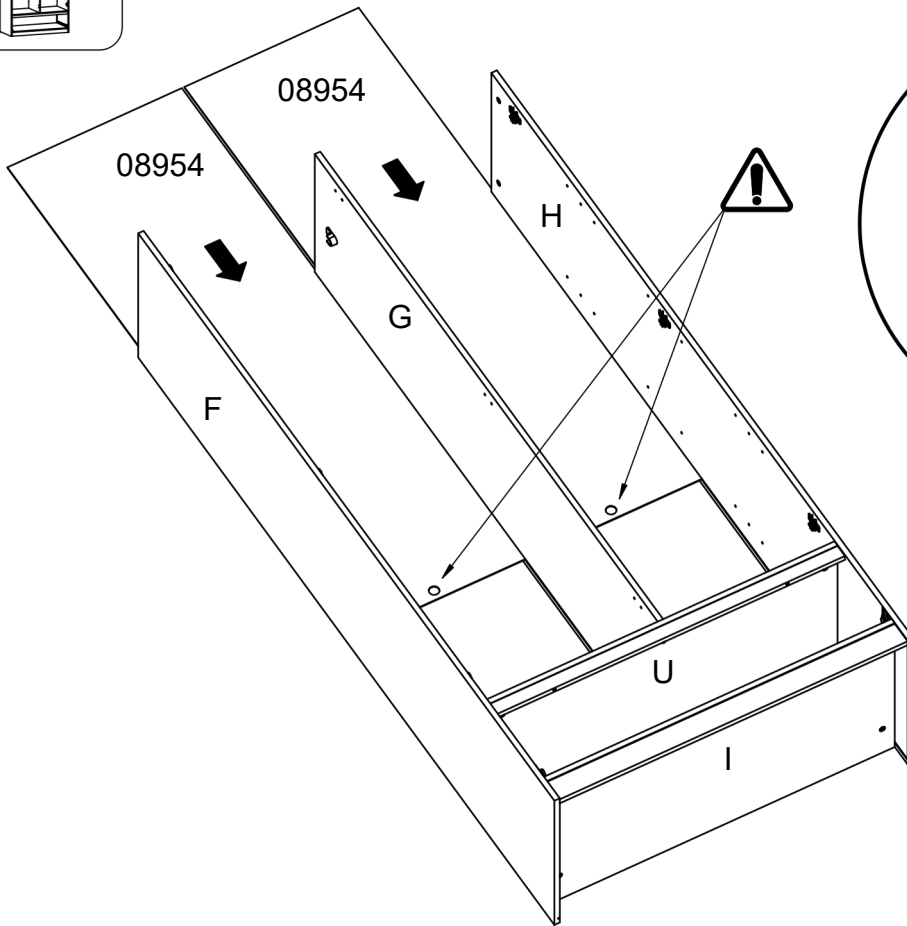
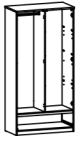

11

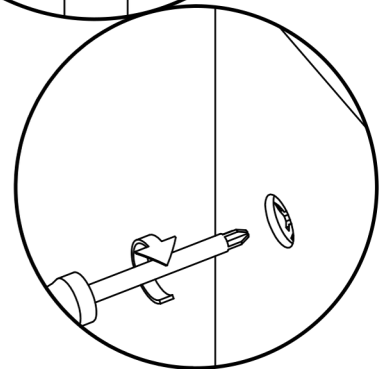
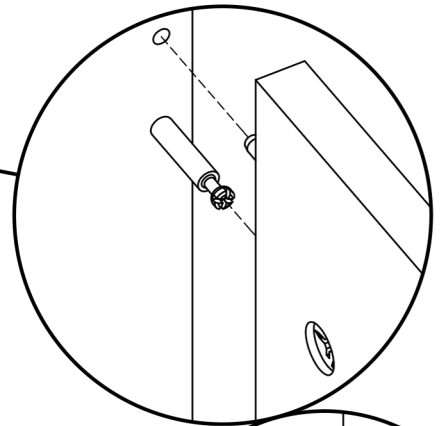
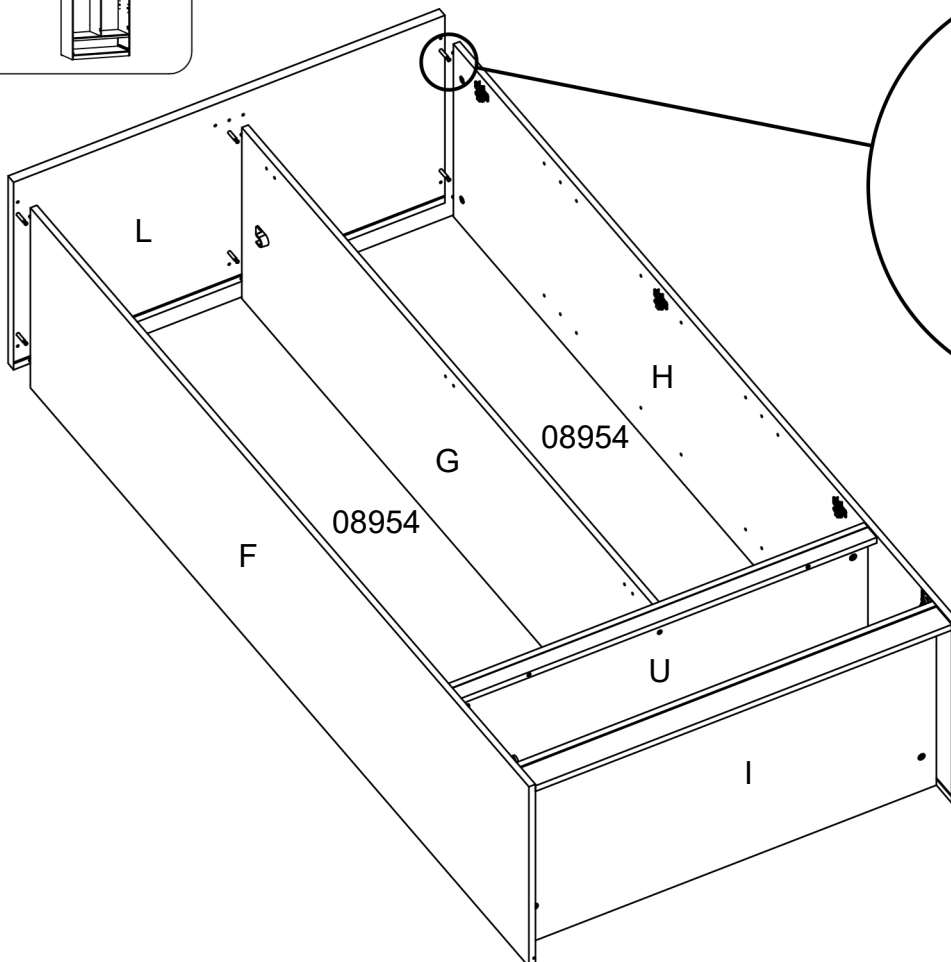
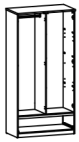

12

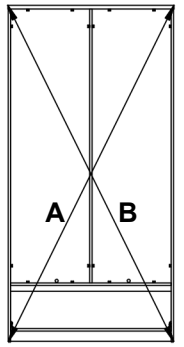
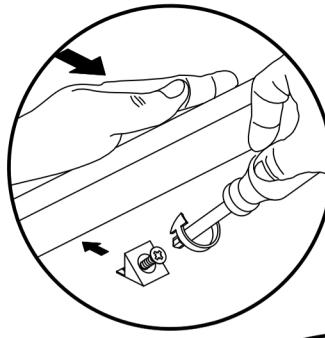
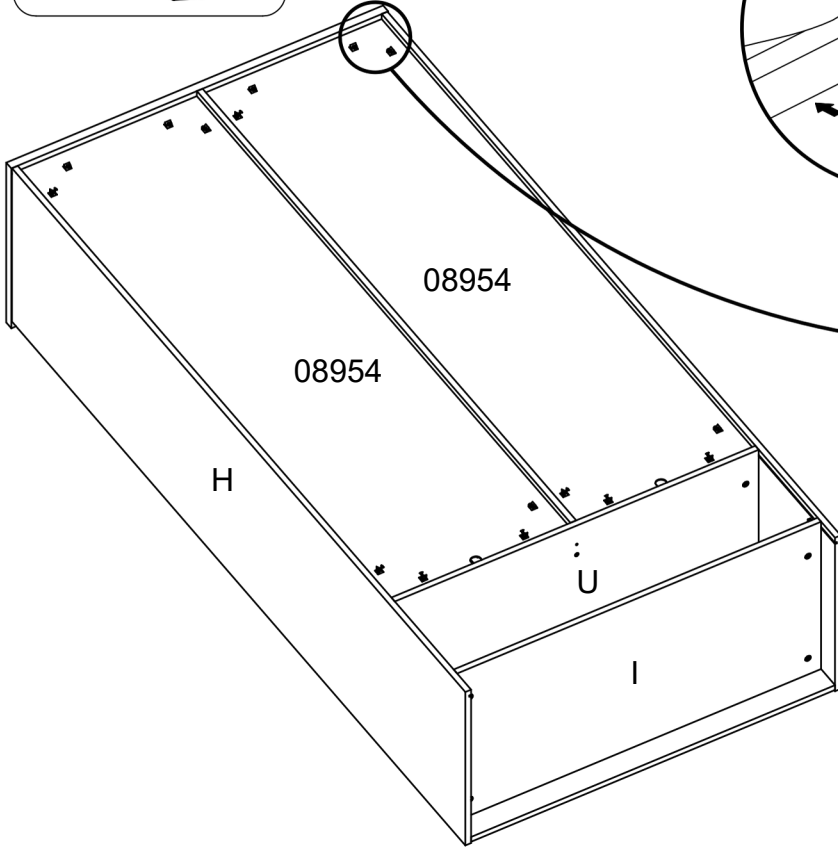
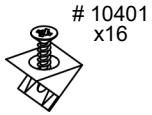
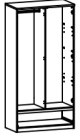

A = B

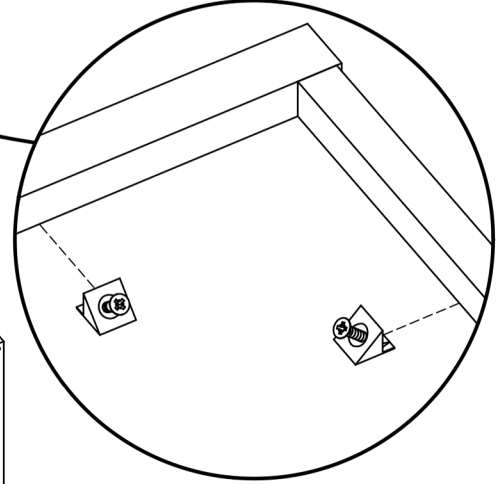
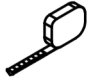

13

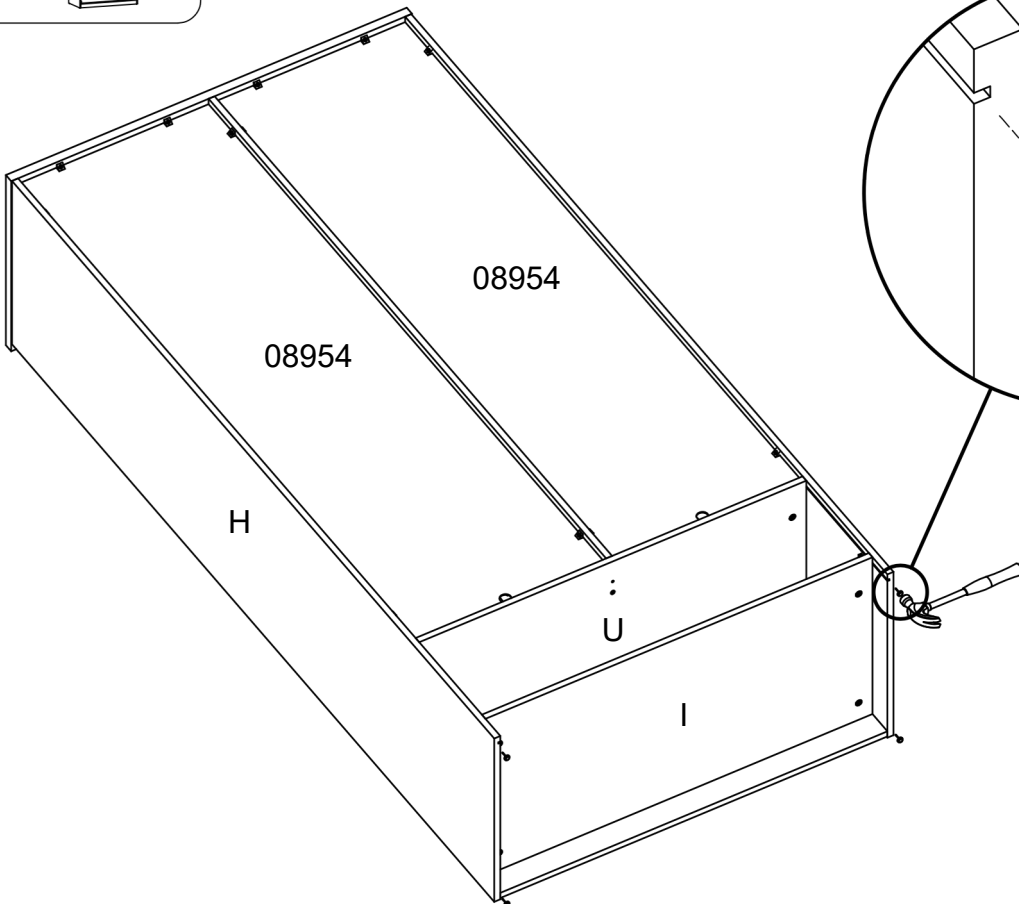
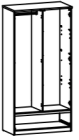

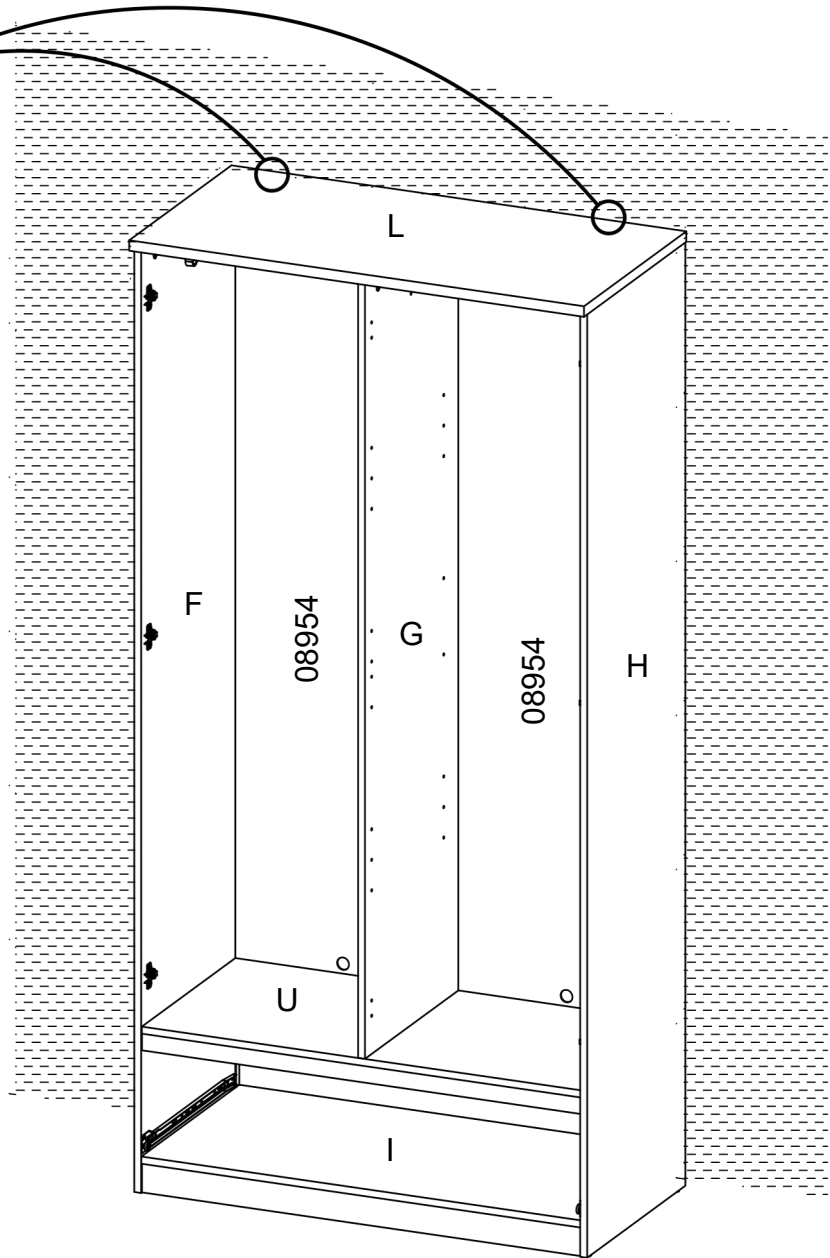
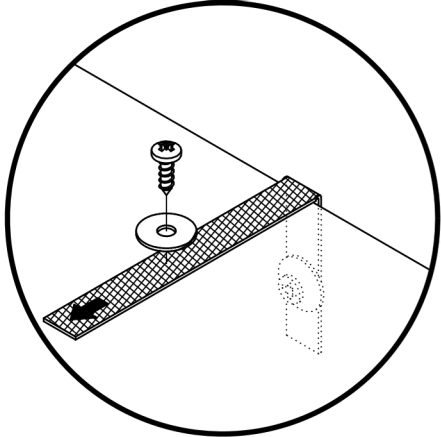
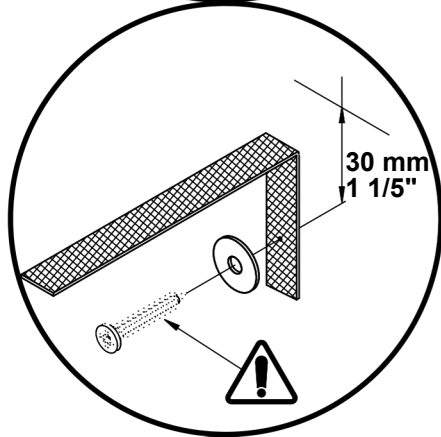
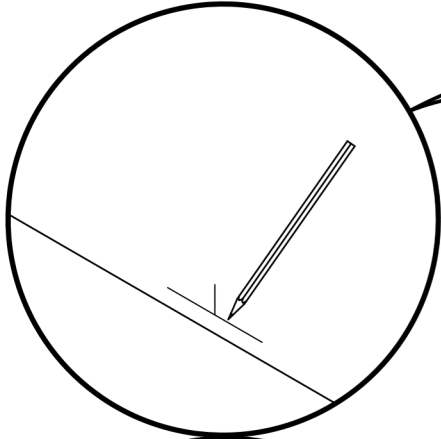
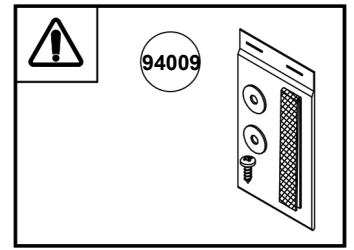
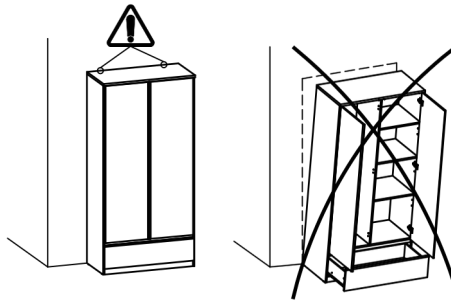
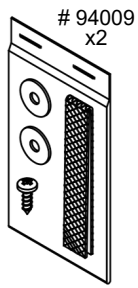
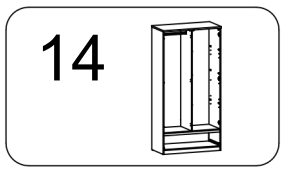

15



26040
x2

92701
x2

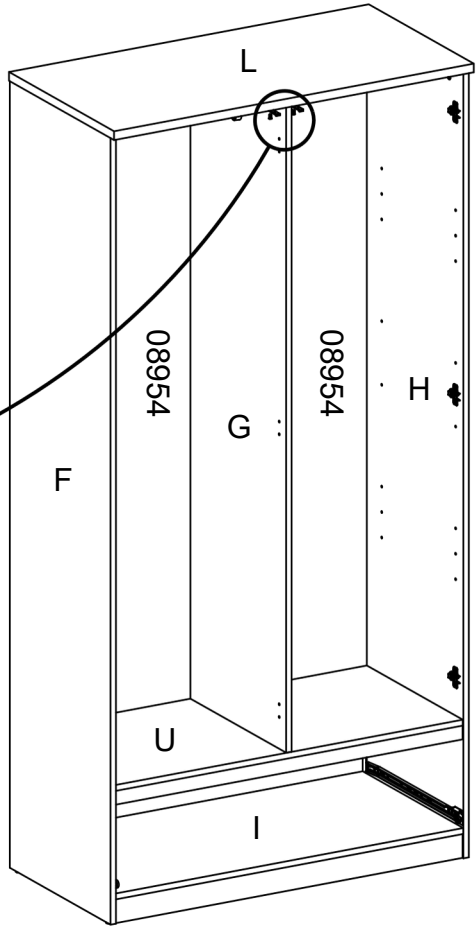
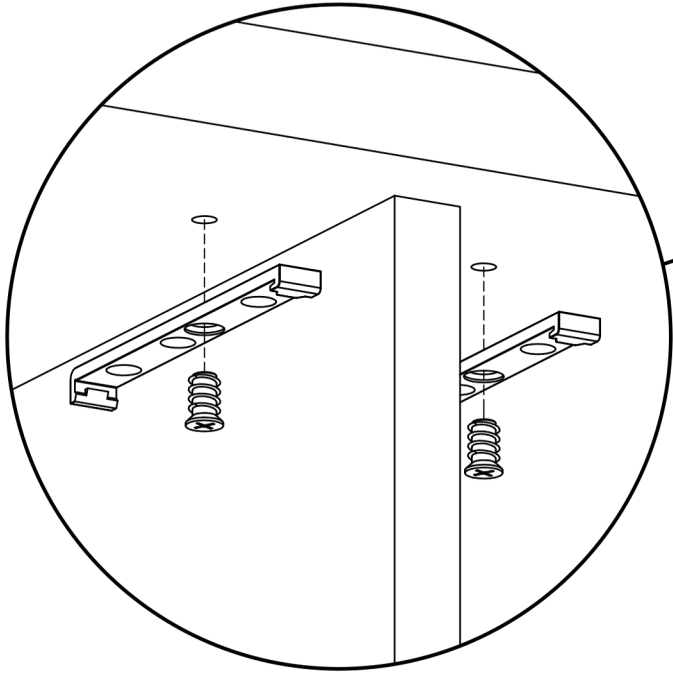
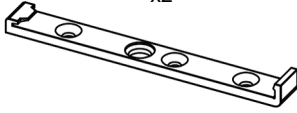

16

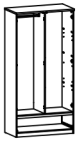

25215
x4

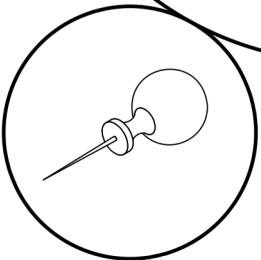
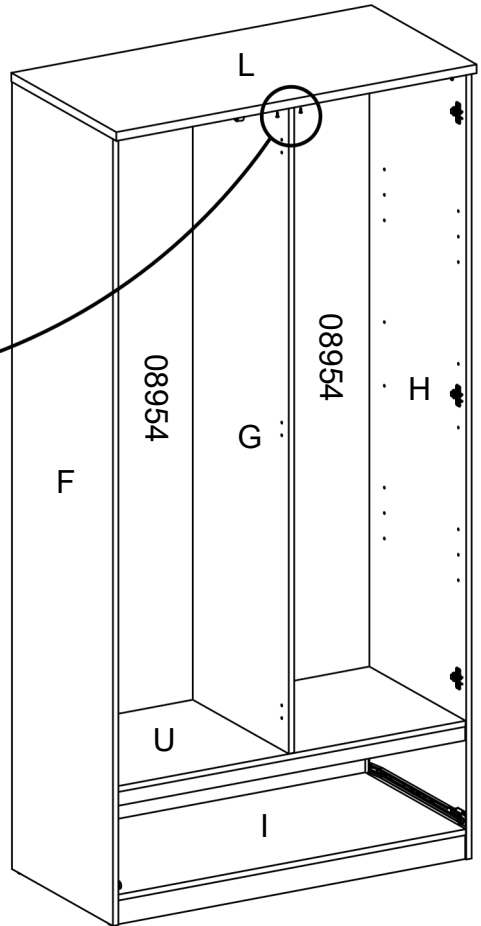
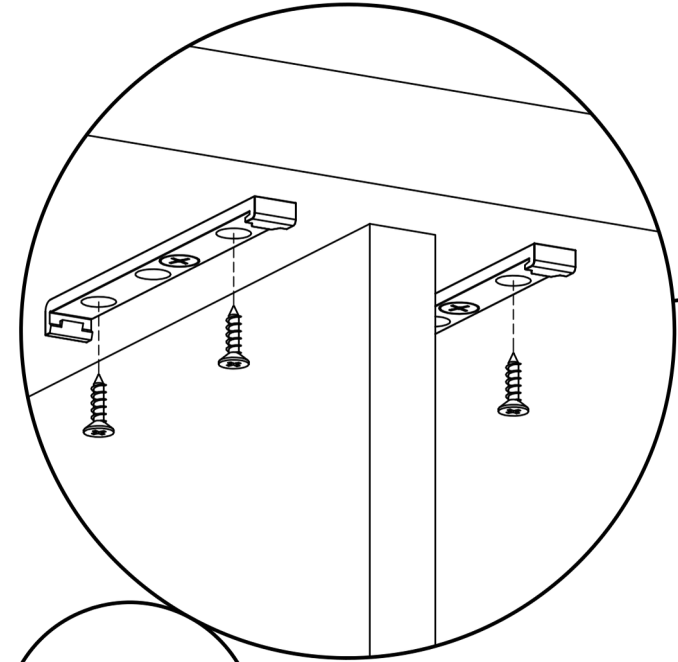

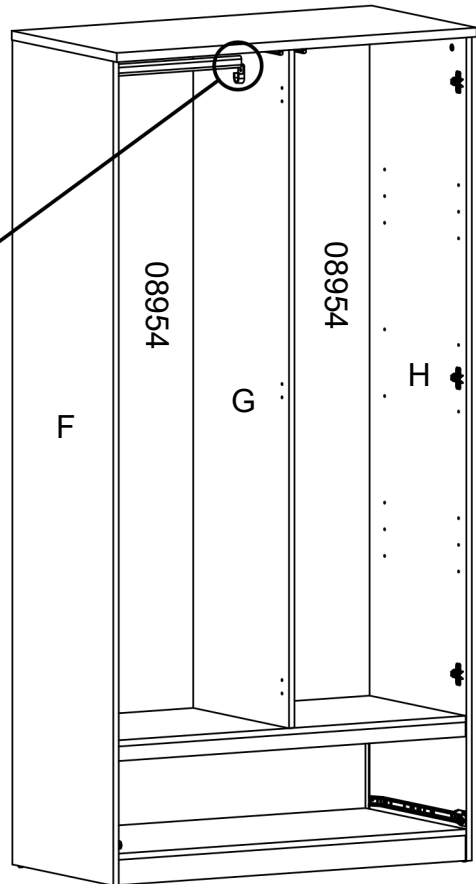
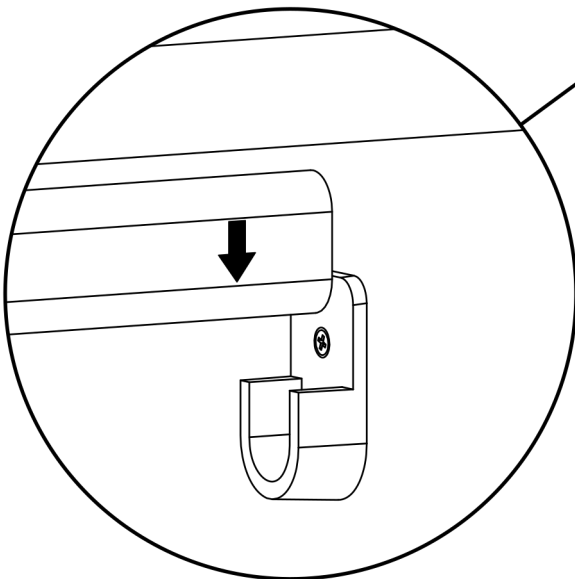
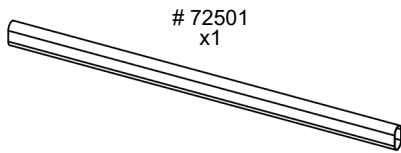
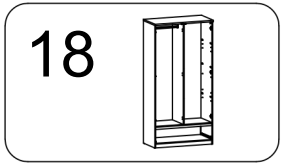
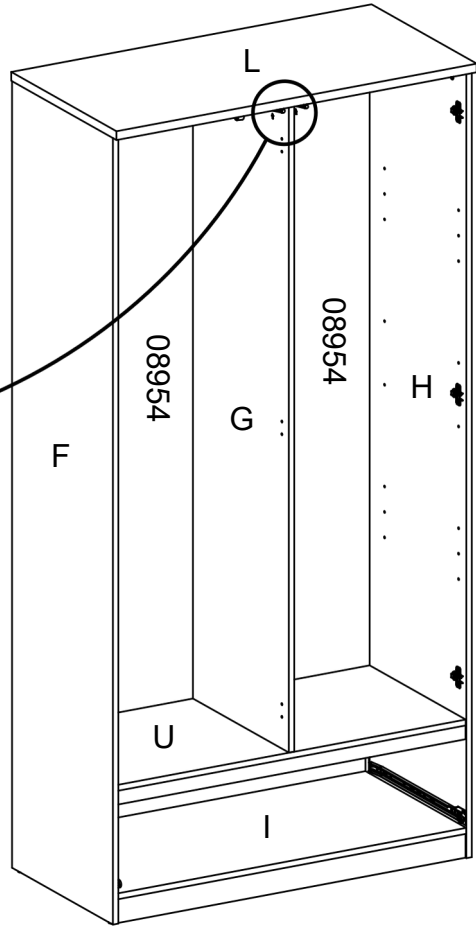
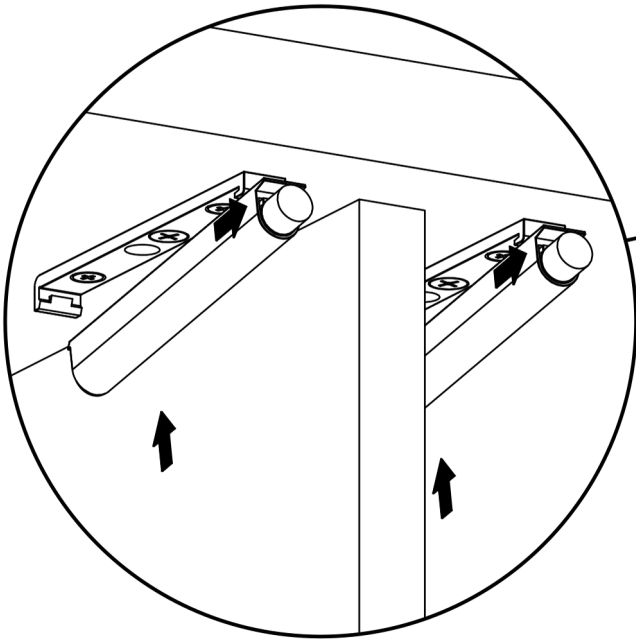
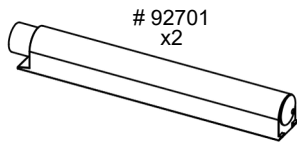
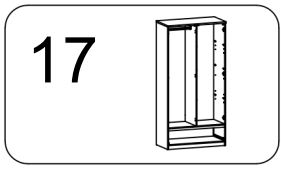

19

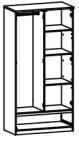

11042
x12

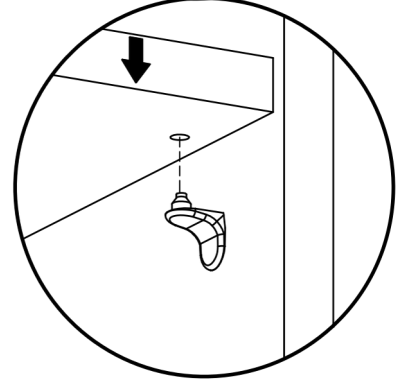
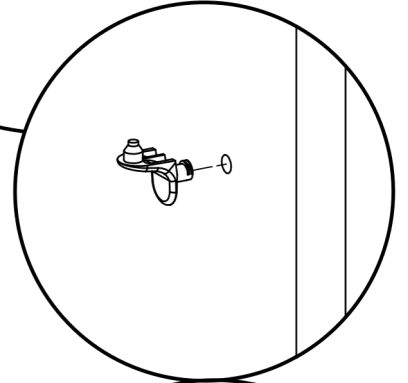
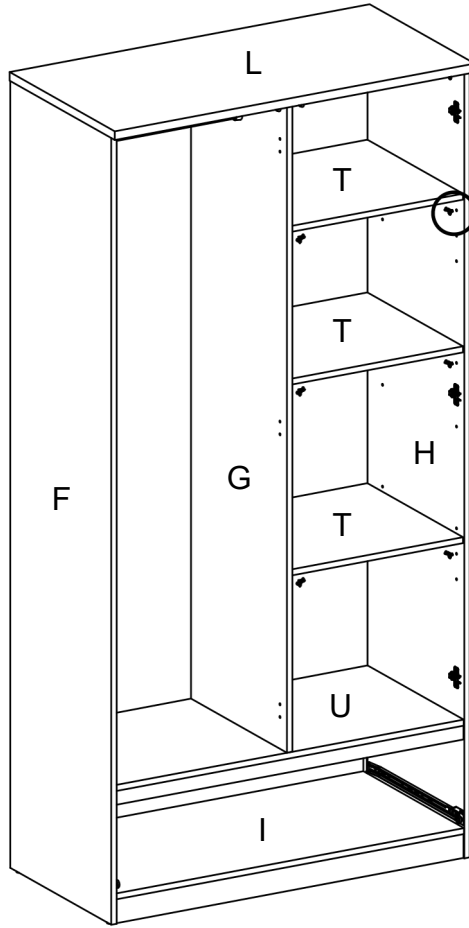

20

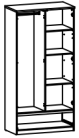

10901
x1

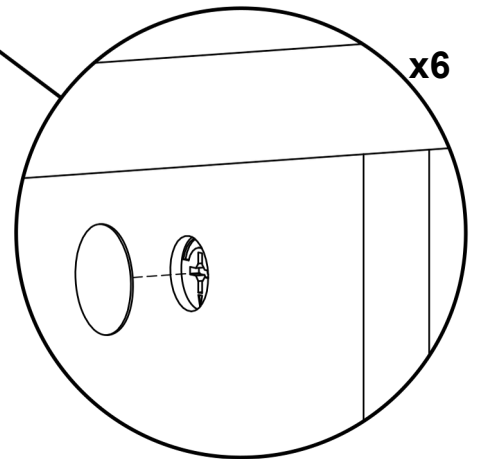
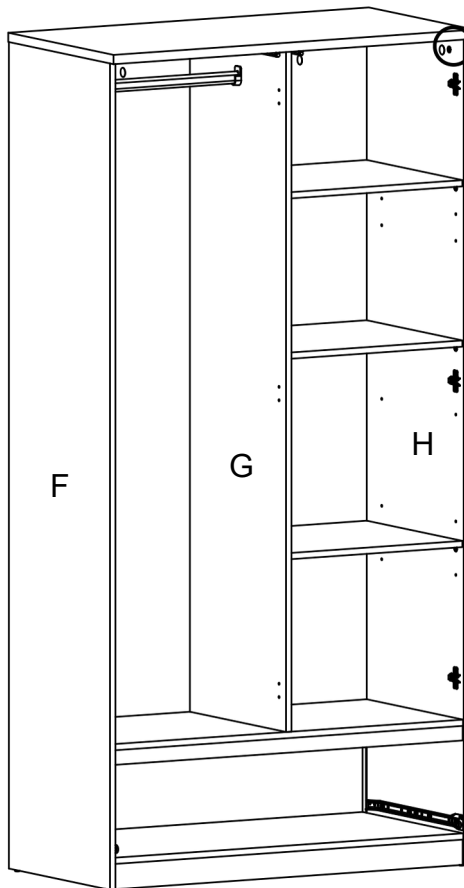
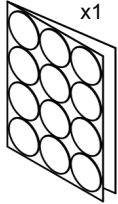

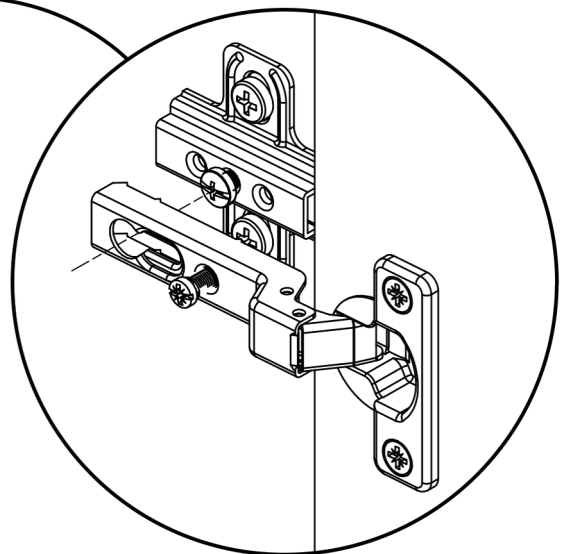
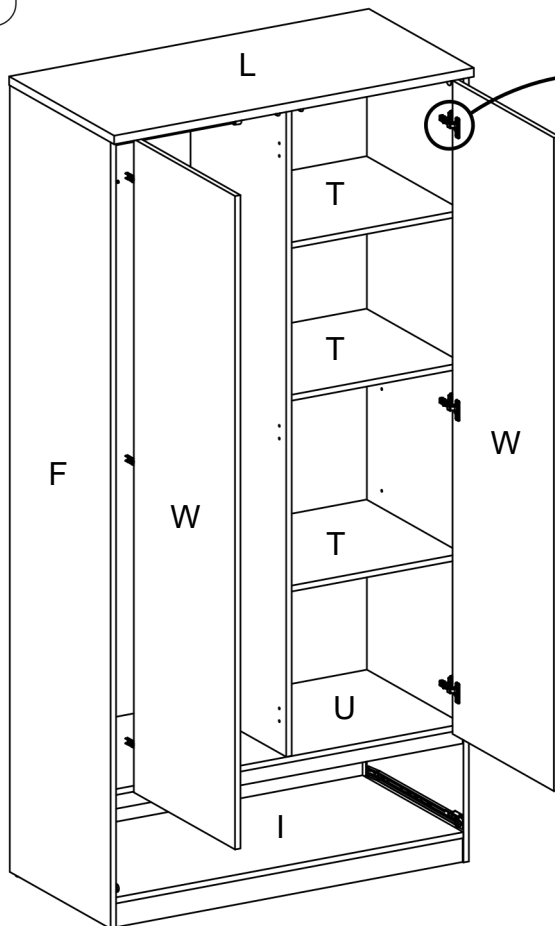
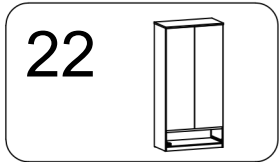
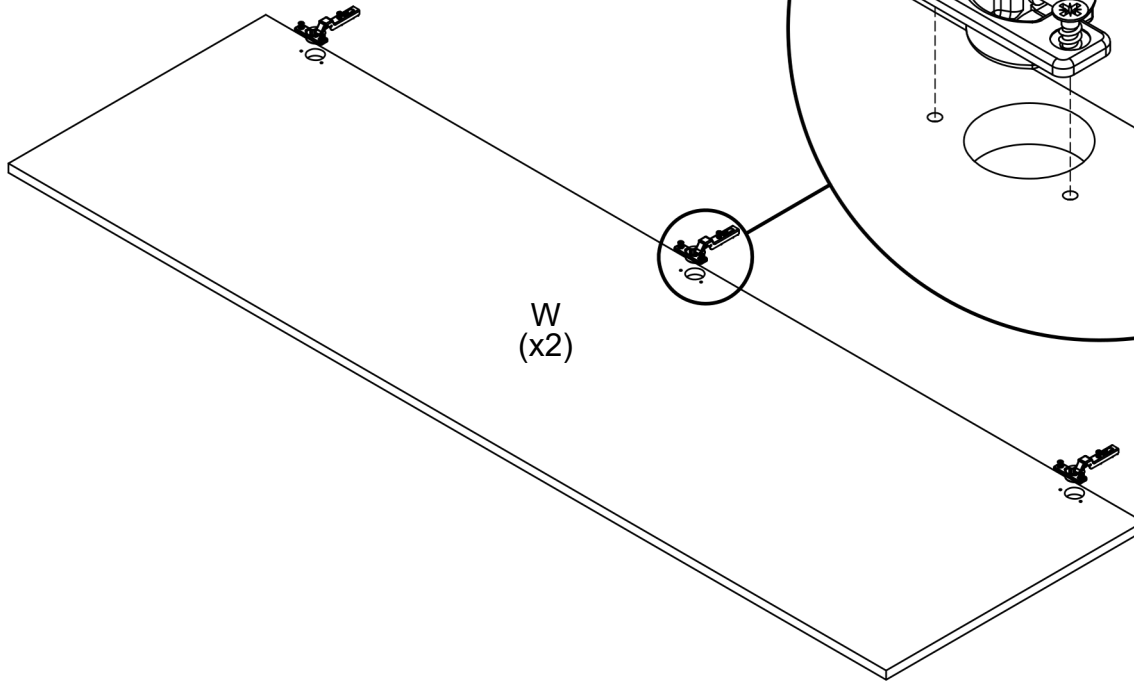
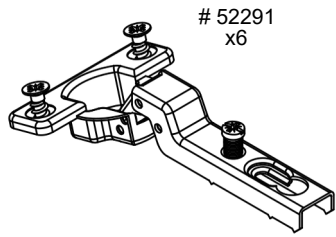
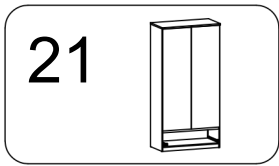

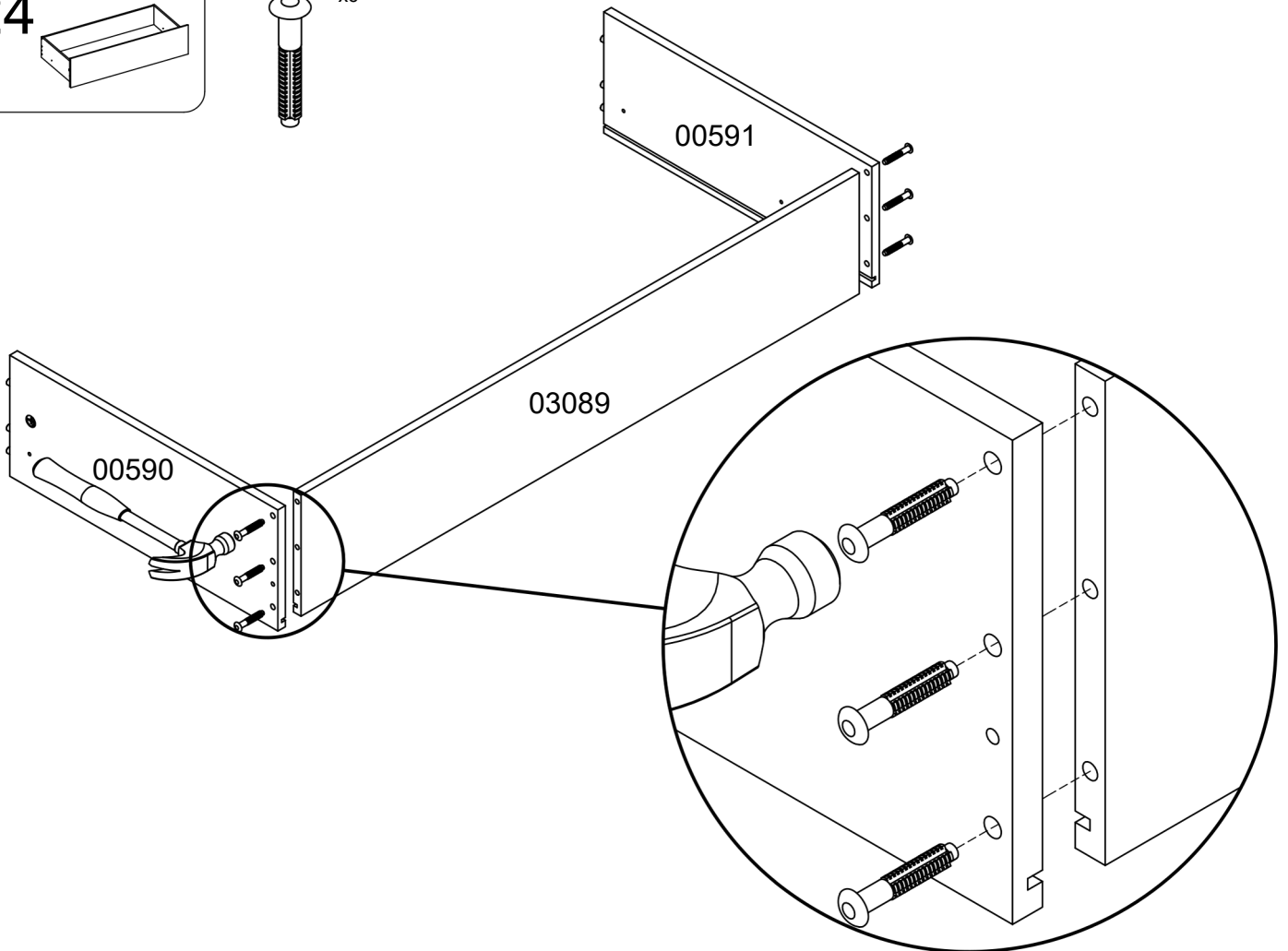
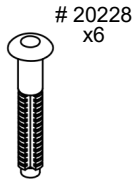
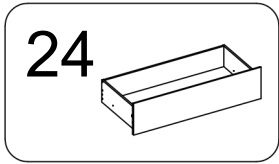
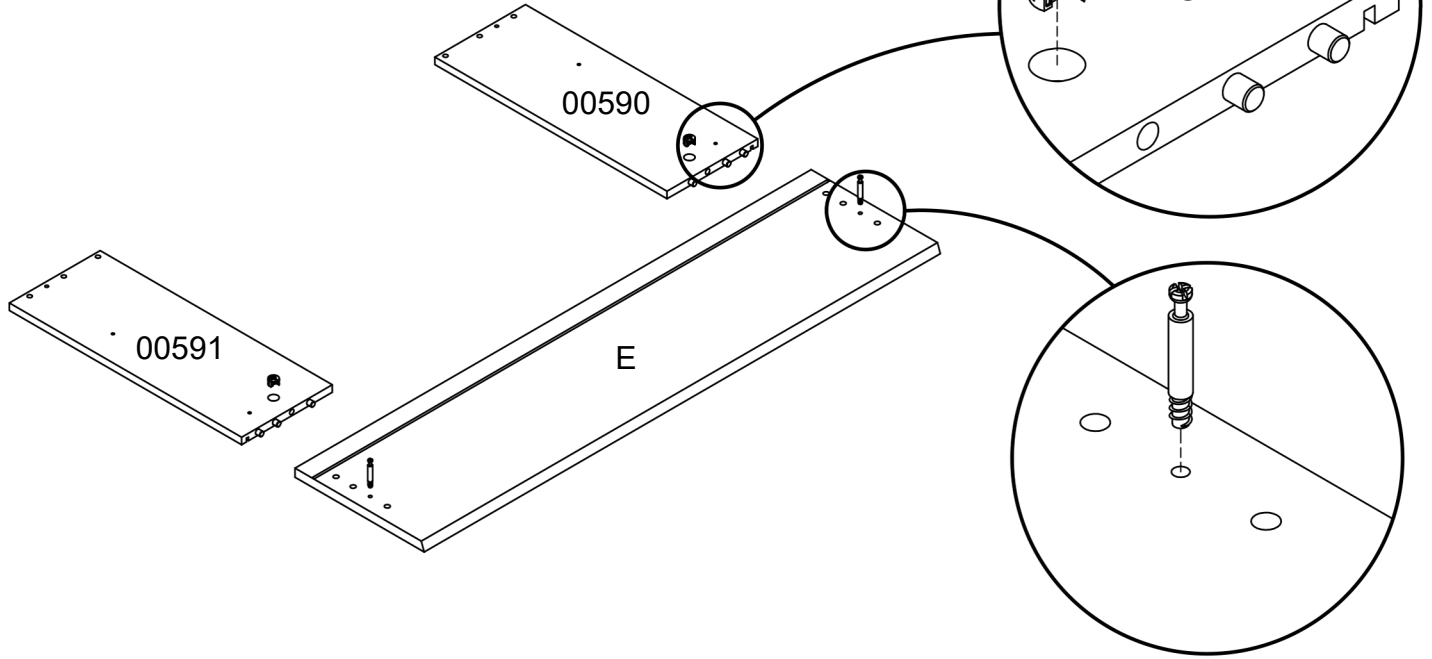
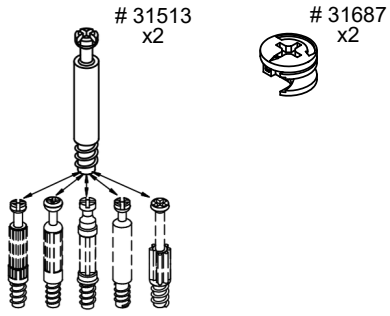
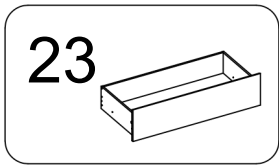

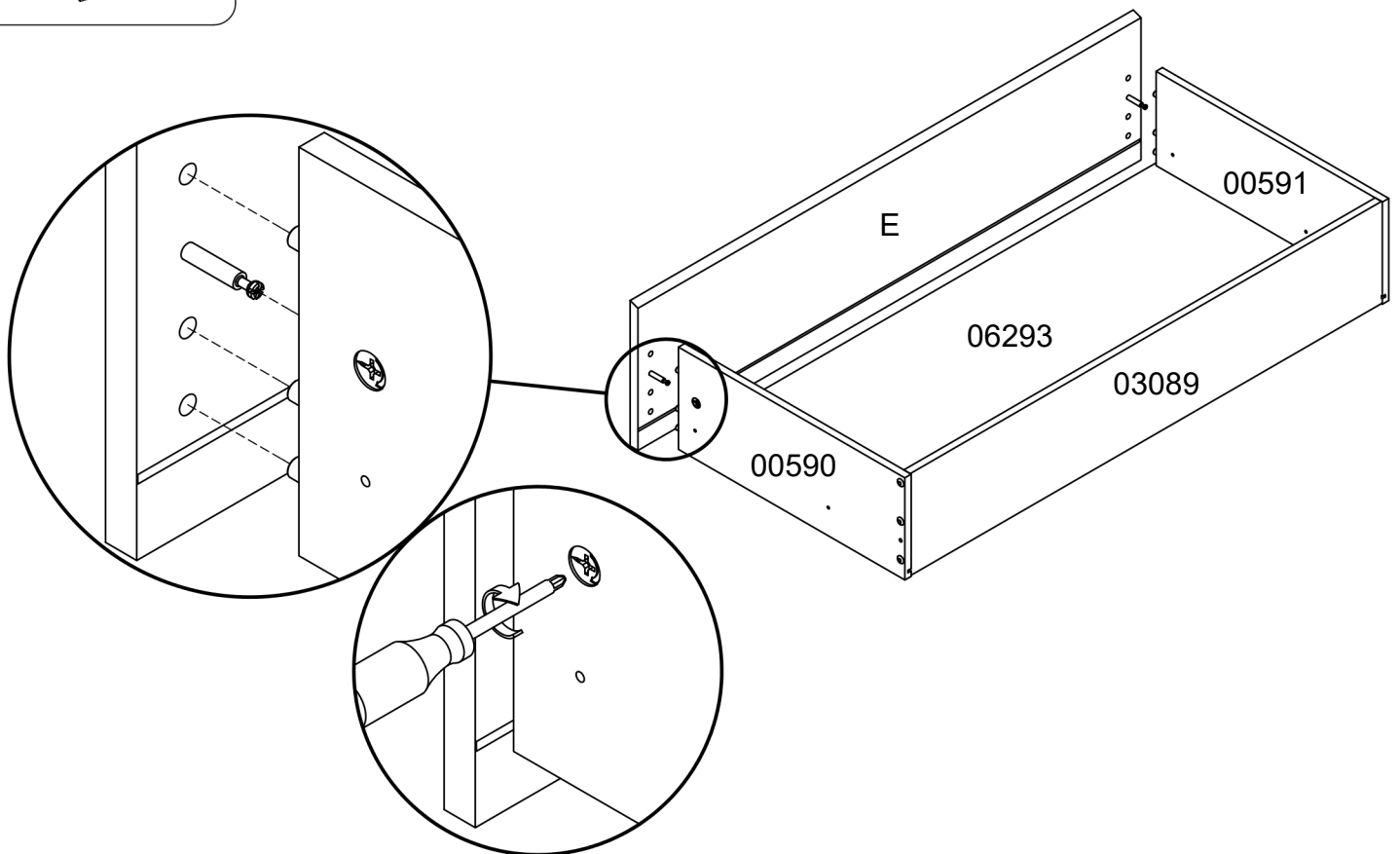
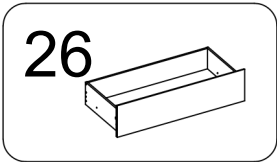
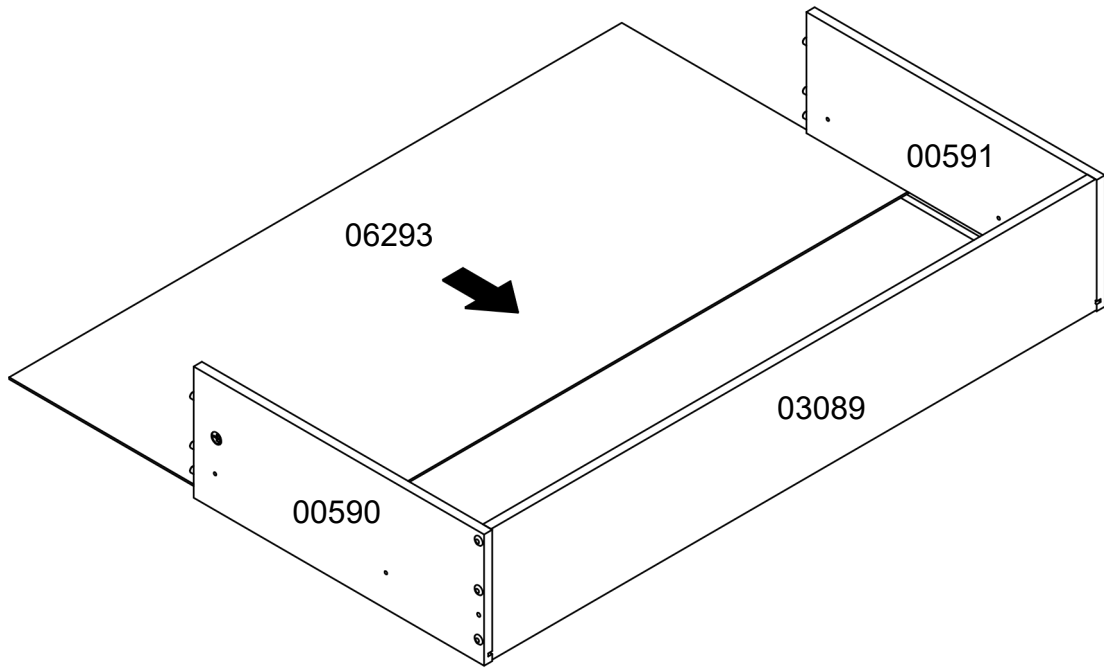
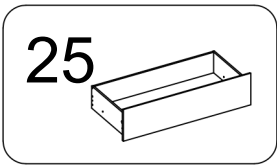

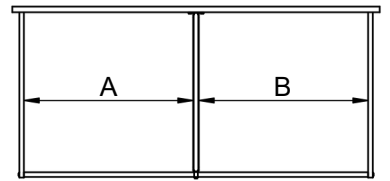
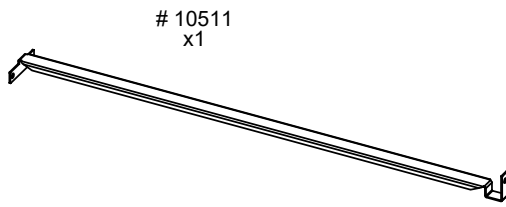
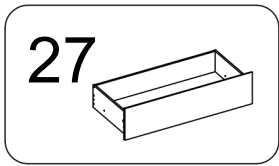

A = B

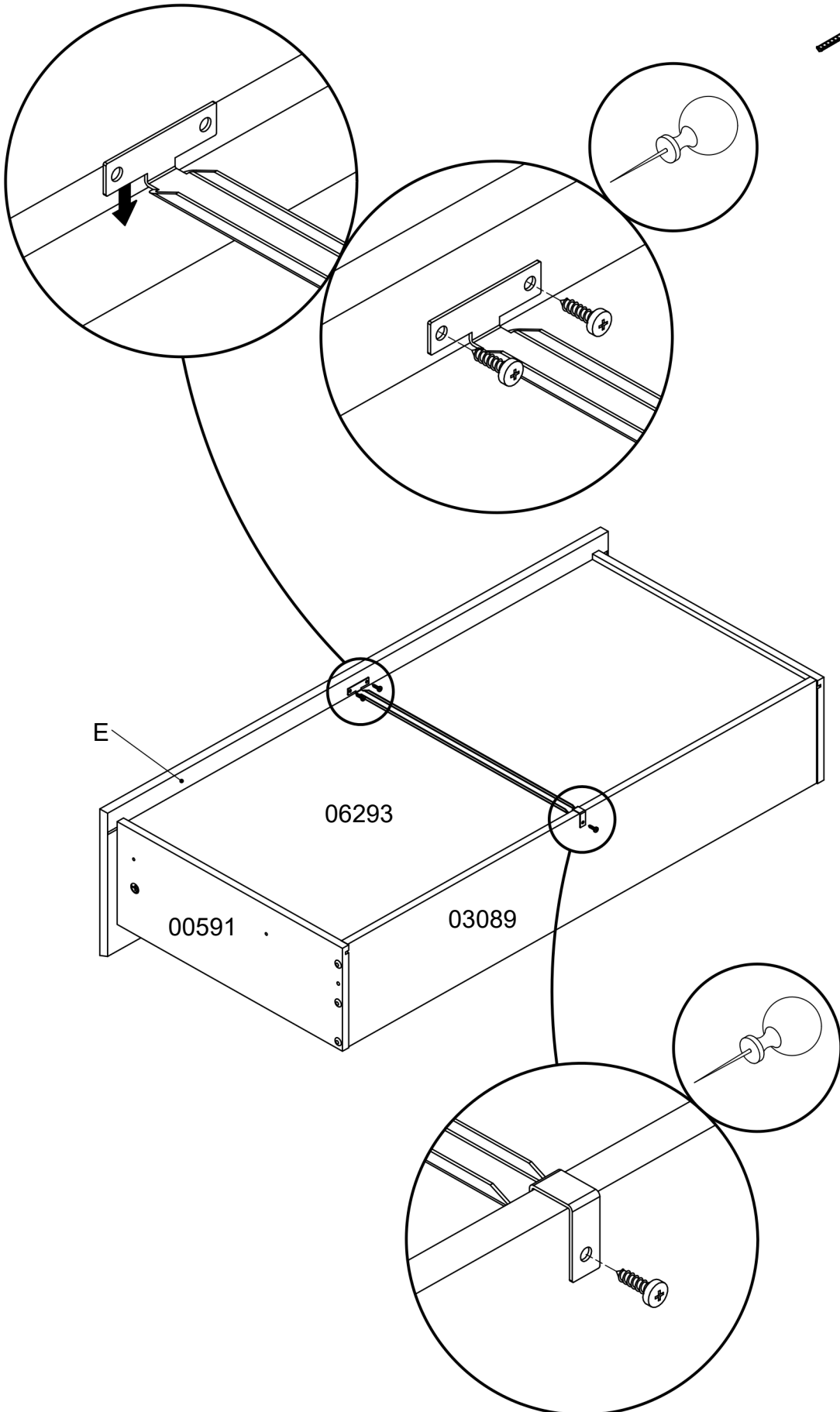

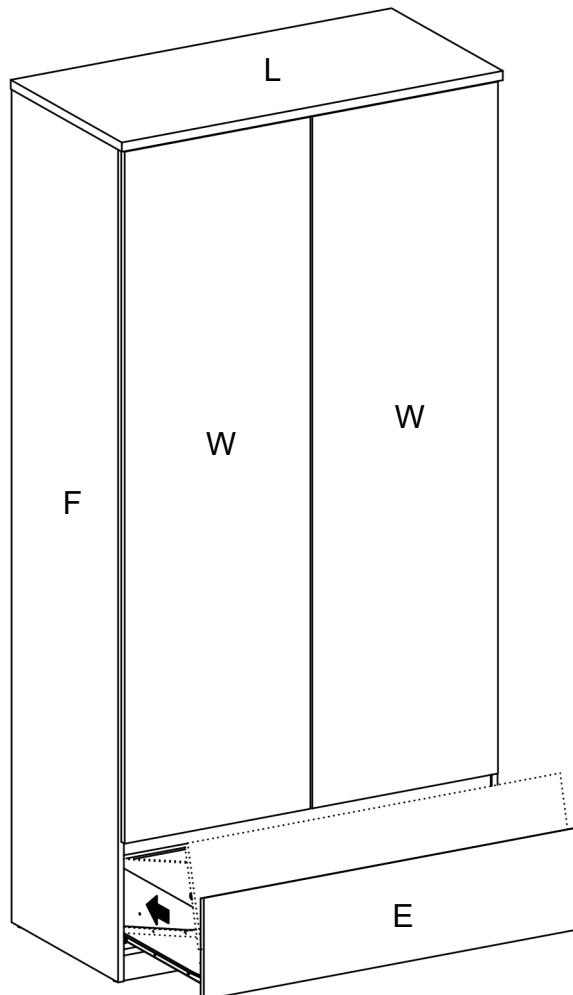
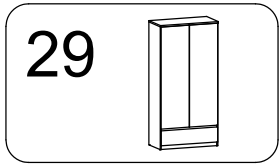
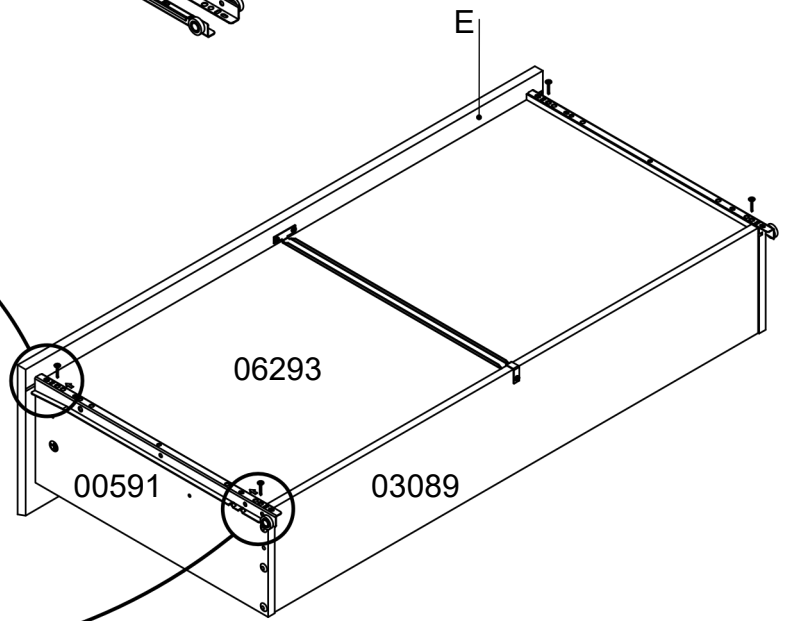
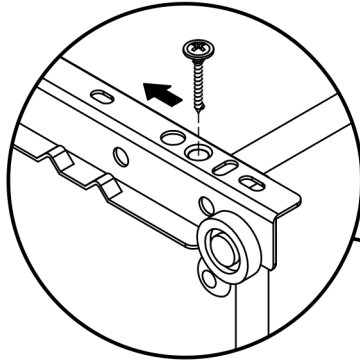
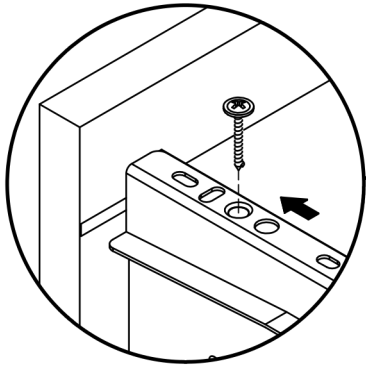
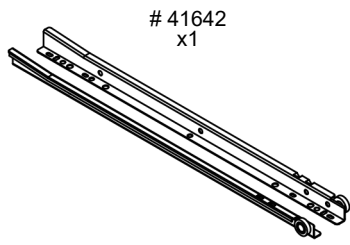
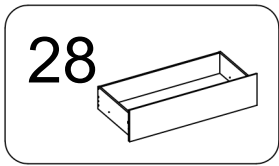

30

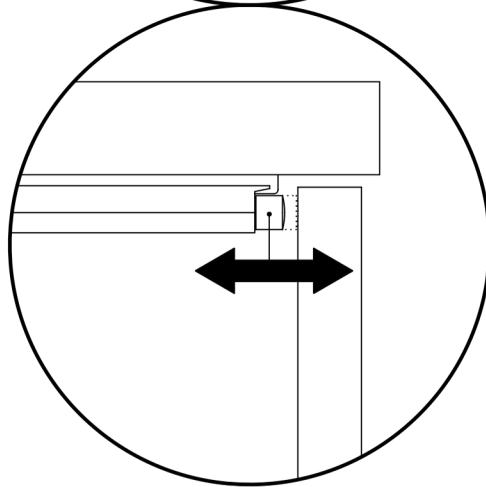
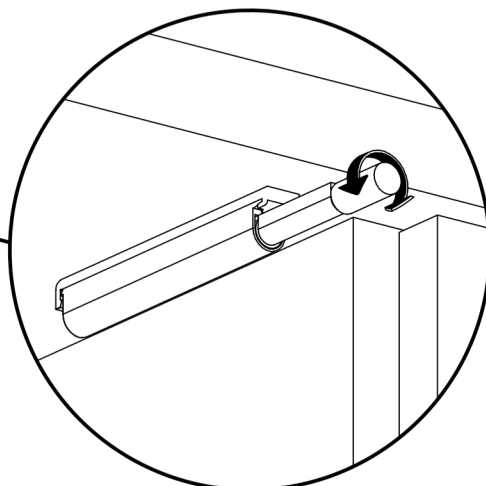
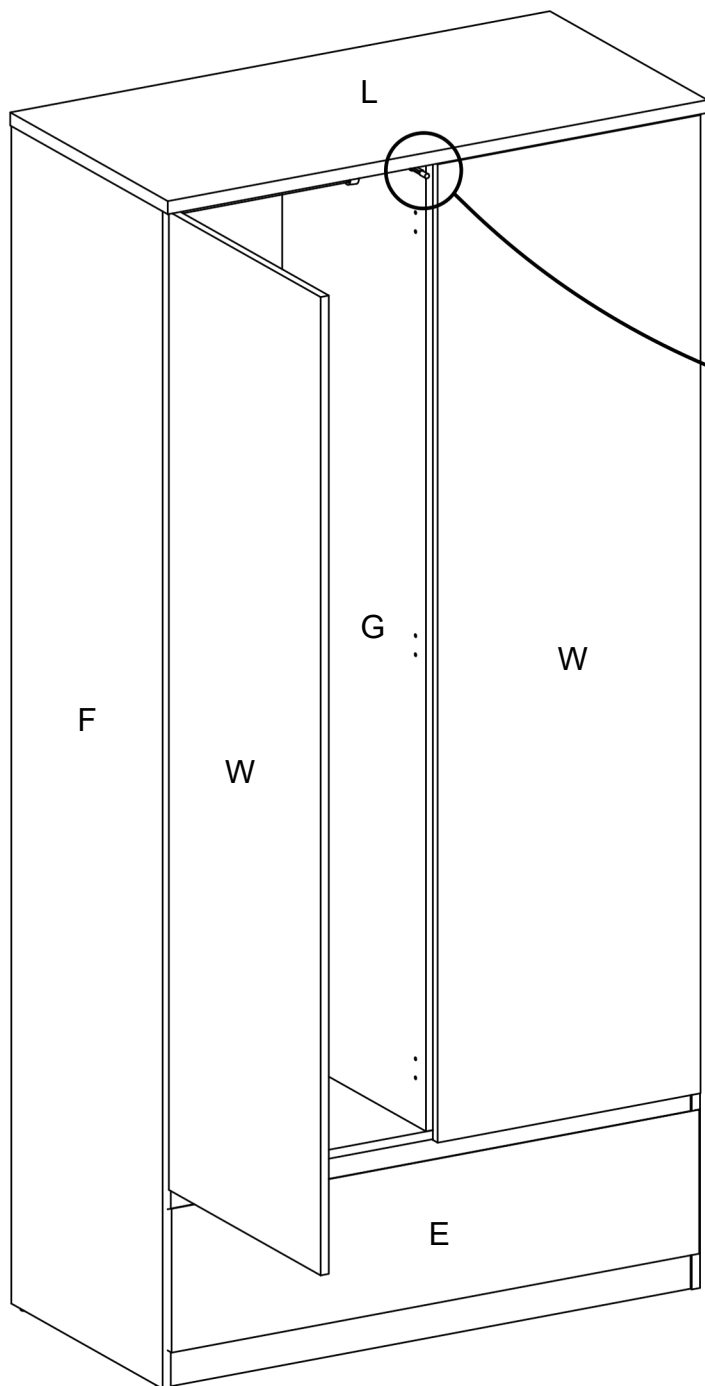
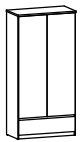

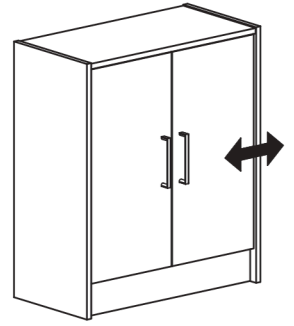
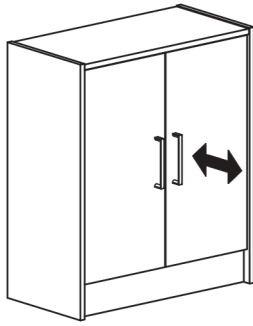
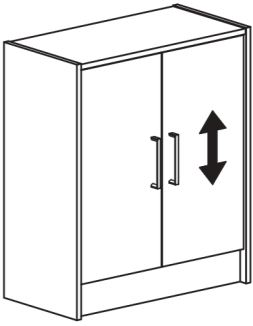

1.

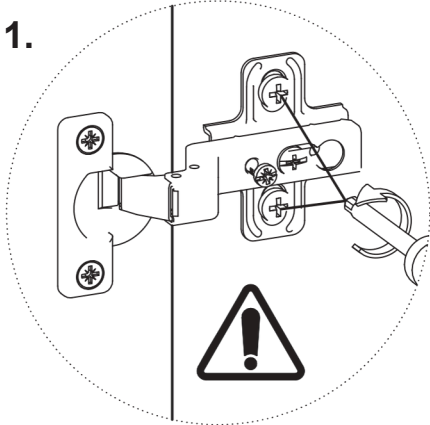

1.

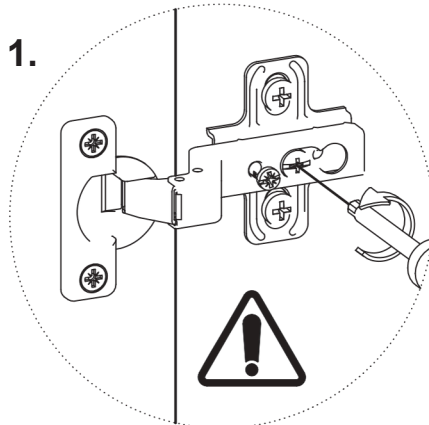

1.

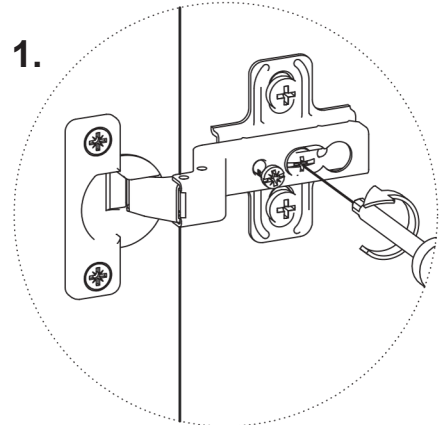

2.

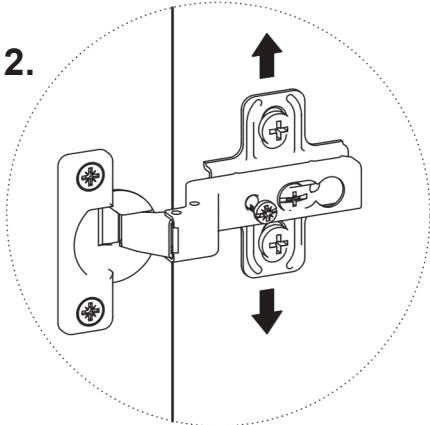

2.

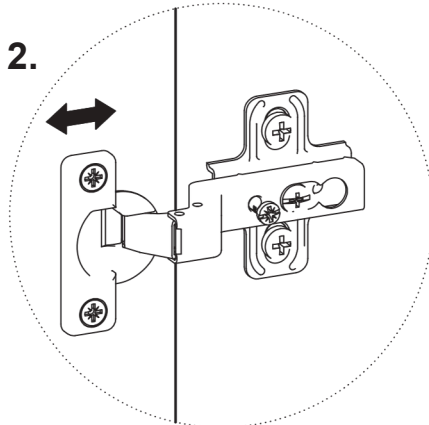

2.

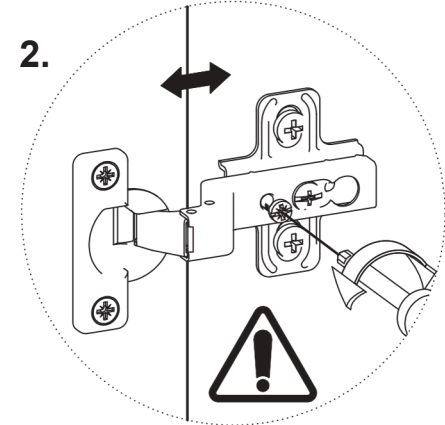

3.

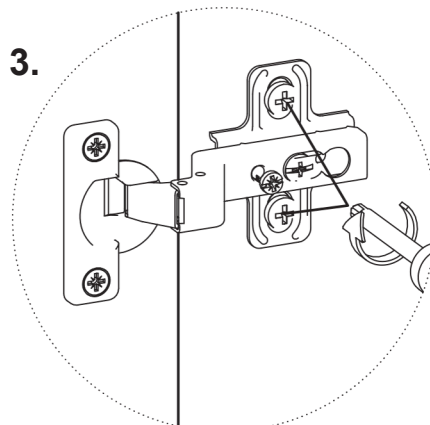

3.

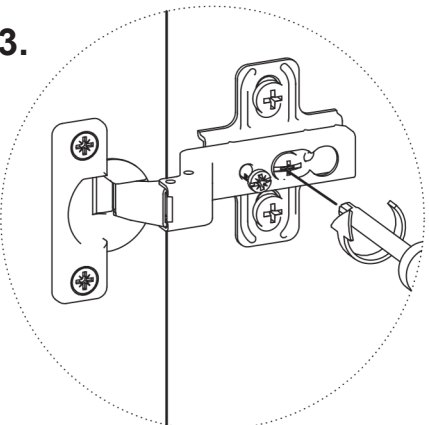

3.

